



bw broadcast

TX150/300 FM Broadcast Transmitter



Technical Manual v2.1

No part of this manual may be re-produced in any form without prior written permission from BW Broadcast. The information and specifications contained in this document is subject to change at any time without notice.
Copyright 2012 BW Broadcast

www.bwbroadcast.com

WARNING

This transmitter should never be operated without a suitable antenna or test dummy load! Failure to observe this requirement may result in damage to the transmitter that is not covered by the warranty.

IMPORTANT

This transmitter has been shipped with the internal stereo generator enabled. The internal jumper J5 (MPX loop-through) is set to ON.

If you intend to connect a MPX signal to the MPX input BNC connector you will need to move J5 (MPX loop-through) to the OFF position.

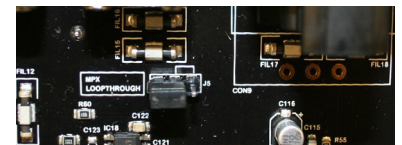

**MPX Loopthrough Jumper
in off position**

Examples of configurations requiring setting J5 to OFF include:

- Routing the internal MPX signal through an external RDS encoder.
- Connecting an external audio processor or stereo generator to the transmitter.
- Connecting a re-broadcast or STL receiver to the transmitter.

Consult the manual for further information on the transmitter's jumpers and connections.

CONTENTS

- 1. Introduction**
 - 1.1 TX FM Transmitter
 - 1.2 Warranty
 - 1.3 Safety
 - 1.4 Quick setups
 - 1.5 Front And Rear Panels
 - 1.6 Control And Monitor LCD

- 2. Installation And Setup**
 - 2.1 Frequency Setup
 - 2.2 R.F. Power Setup
 - 2.3 Alarms
 - 2.4 RS232 Control & Monitoring
 - 2.41 Windows remote control application
 - 2.42 Terminal control of the transmitter
 - 2.5 Modes Of Operation
 - 2.51 A guide to the jumpers
 - 2.52 Multiplex / Broadband Input
 - 2.53 Stereo
 - 2.54 Mono
 - 2.6 Other Setup Considerations

- 3. Technical data**
 - 3.1 Specifications
 - 3.2 Circuit Description
 - 3.21 Combo board
 - 3.22 LCD control board
 - 3.23 Power amplifier board
 - 3.3 Block Diagram
 - 3.4 Internal Wiring / Case Overview
 - 3.5 Schematics
 - 3.51 Combo section
 - 3.511 DSP Limiter section
 - 3.512 Stereo Encoder section
 - 3.513 Exciter section
 - 3.514 Digital Input Section
 - 3.52 LCD control section
 - 3.53 Power amplifier section
 - 3.6 Parts List
 - 3.61 Combo board parts list
 - 3.62 LCD control board parts list
 - 3.63 Power amplifier board parts list

1.1 TX150+/300+ FM TRANSMITTER

The BW Broadcast TX150+/300+ is a high specification FM broadcast transmitter. Its broadband “no-tune” design allows 87.5-108 MHz operation from internal direct reading rotary switches or the front panel LCD frequency control system if enabled. Digital PWM techniques provide an easily adjustable and accurate automatic level controlled R.F. output of the MOS-FET power amplifier stage. With integrated multi-band DSP technology the TX150+/300+ ideal for creating a loud, punchy, on-air presence.

A metering system offering accuracy normally found on specialist test equipment is available at a glance on the LCD graphics display. Partnered with the simple controls and clear menus a new level of ease of setup and installation is achieved. Local and remote personal computer control and metering are achievable via RS232 interface and there's an alarm I/O and trigger I/O connectors for full system flexibility.

The four band digital signal processor features automatic gain control, multiband leveling, and distortion cancelling clippers to limit audio level; keeping your signal to a maximum in both level and quality.

The FM modulator section employs a dual speed “virtual VFO” system for extremely low audio distortion and excellent stereo performance. A built in high specification stereo encoder provides crystal clear stereo sound and combined with the internal limiter a fully compliant “plug and play” all in one low power broadcast transmitter.

For future compatibility all settings are switchable with on board jumpers and dip switches. The stereo and processing settings can be switched in and out to suit the requirements of any external broadcast equipment you may have now and in the future.

The lightweight mains input design ensures a high reliability efficient design compatible with any mains system in the world.

1.2 WARRANTY

BW Broadcast warrants the mechanical and electronic components of this product to be free of defects in material and workmanship for a period of two (2) years from the original date of purchase, in accordance with the warranty regulations described below. If the product shows any defects within the specified warranty period that are not due to normal wear and tear and/or improper handling by the user, BW Broadcast shall, at its sole discretion, either repair or replace the product. If the unit has a manufacturer's fault within twenty eight (28) days then BW Broadcast will pay the freight at their discretion. If the warranty claim proves to be justified, the product will be returned to the user freight prepaid. Warranty claims other than those indicated above are expressly excluded.

Return authorisation number

To obtain warranty service, the buyer (or his authorized dealer) must call BW Broadcast during normal business hours BEFORE returning the product. All inquiries must be accompanied by a description of the problem. BW Broadcast will then issue a return authorization number.

Subsequently, the product must be returned in its original shipping carton, together with the return authorization number to the address indicated by BW Broadcast. Shipments without freight prepaid will not be accepted.

Warranty regulations

Warranty services will be furnished only if the product is accompanied by a copy of the original retail dealer's invoice. Any product deemed eligible for repair or replacement by BW Broadcast under the terms of this warranty will be repaired or replaced within 30 days of receipt of the product at BW Broadcast.

If the product needs to be modified or adapted in order to comply with applicable technical or safety standards on a national or local level, in any country which is not the country for which the product was originally developed and manufactured, this modification/adaptation shall not be considered a defect in materials or workmanship. The warranty does not cover any such modification/adaptation, irrespective of whether it was carried out properly or not. Under the terms of this warranty, BW Broadcast shall not be held responsible for any cost resulting from such a modification/adaptation.

Free inspections and maintenance/repair work are expressly excluded from this warranty, in particular, if caused by improper handling of the product by the user. This also applies to defects caused by normal wear and tear, in particular, of faders, potentiometers, keys/buttons and similar parts.

Damages/defects caused by the following conditions are not covered by this warranty:

Misuse, neglect or failure to operate the unit in compliance with the instructions given in BW Broadcast user or service manuals. Connection or operation of the unit in any way that does not comply with the technical or safety regulations applicable in the country where the product is used. Damages/defects caused by force majeure or any other condition that is beyond the control of BW Broadcast. Any repair or opening of the unit carried out by unauthorized personnel (user included) will void the warranty.

If an inspection of the product by BW Broadcast shows that the defect in question is not covered by the warranty, the inspection costs are payable by the customer.

Products which do not meet the terms of this warranty will be repaired exclusively at the buyer's expense. BW Broadcast will inform the buyer of any such circumstance. If the buyer fails to submit a written repair order within 6 weeks after notification, BW Broadcast will return the unit C.O.D. with a separate invoice for freight and packing. Such costs will also be invoiced separately when the buyer has sent in a written repair order.

Warranty transferability

This warranty is extended exclusively to the original buyer (customer of retail dealer) and is not transferable to anyone who may subsequently purchase this product. No other person (retail dealer, etc.) shall be entitled to give any warranty promise on behalf of BW Broadcast.

Claims for damages

Failure of BW Broadcast to provide proper warranty service shall not entitle the buyer to claim (consequential) damages. In no event shall the liability of BW Broadcast exceed the invoiced value of the product.

Other warranty rights and national law

This warranty does not exclude or limit the buyer's statutory rights provided by national law, in particular, any such rights against the seller that arise from a legally effective purchase contract. The warranty regulations mentioned herein are applicable unless they constitute an infringement of national warranty law.

1.3 SAFETY

MAINS VOLTAGE

This equipment operates from an AC power source of between 90 and 265 volts. There are hazardous voltages present internally. PLEASE OBSERVE CAUTION WITH THE COVER REMOVED.

SWITCHED MODE POWER SUPPLY HAZARD

Please note that the power supply units in this equipment is of the switched mode variety and have lethal voltages present internally. The switched mode supplies are universal input fully approved type. They are non serviceable modules and should be fully replaced should they fail.

FUSES

Only use fuses with the specified voltage and current ratings as stated on the back panel. Failure to do so may increase the risk of equipment failure, shock and fire hazard.

R.F.

The N type R.F. power output socket contains R.F. voltages which may burn or present a shock. Please make sure that the equipment is connected to an adequately rated load or antenna system while in operation.

TOXIC HAZARD

This equipment includes R.F. components that may contain Beryllium oxide which is a highly toxic substance that could be hazardous to health if inhaled or ingested. Care should be taken when replacing or discarding such devices. Seek expert advice from the manufacturer should you physically damage a device that contains Beryllium Oxide. The main R.F. output power transistor contains Beryllium oxide.

OTHER SAFETY CONSIDERATIONS

Do not operate this equipment in the presence of flammable gases, fumes or liquids

Do not expose this equipment to rain or water.

CE CONFORMANCE

This device complies with the requirements of the 1995/5/EC Radio and Telecommunications Terminal Equipment (R&TTE). The equipment will meet or exceed the following standards: EN 60215:1996 (Safety Requirements for Radio Transmitting Equipment), EN 301 489-11 (ERM/EMC for Radio Equipment, Part 11 Specific Conditions for FM Transmitters), EN 302 018-2 ERM (Transmitting Equipment for FM Radio Broadcasting service)



The operating frequencies of this transmitter may not be harmonised in the intended countries of use. The user must obtain a license before using the product in the intended country of use. Ensure respective country licensing requirements are complied with. Limitations of use can apply in respect of operating frequency, transmitter power and/or channel spacing.

WEEE COMPLIANCE

BW Broadcast Ltd is registered with Northern Compliance PCS number WEE/P3438PR/SCH and has been issued with WEE/FA0268RX as its unique producer ID by the appropriate environment agency. BW Broadcast Ltd full comply with its explicit responsibilities, subject to WEEE Collections Policy outlined in their General Terms and conditions of Sale, when it sells Electrical and Electronic Equipment (EEE) to B2B customers in the UK and EU.



This appliance has been designed and manufactured with high quality materials and components that can be recycled and reused. Electronic appliances are liable to contain parts that are necessary in order for the system to work properly but which can become a health and environmental hazard if they are not handled and disposed of in the proper way. Consequently, please do not throw your inoperative appliance with the household waste. Having purchased this appliance it is your responsibility to dispose of this equipment appropriately.

1.4 Quick set-up guide

Using a transmitter stand-alone (without RDS encoder)

This set-up uses the built-in audio limiter and stereo generator. The transmitter as shipped from factory is already configured for this set-up, so there are no internal changes to be made.

1. Place a transmitter in a well ventilated space. If it's rack-mounted, leave at least 1U free above and below it for adequate cooling.
2. Connect the antenna to the RF output connector on the back of the transmitter.
3. Connect the left and right program audio signals to the XLR input connectors on the back of the transmitter.
4. Plug the power cord into the power supply module on the rear panel of the transmitter.
5. Once the transmitter is operating, set the correct carrier frequency from the front panel (this can also be locked and set internally).
6. Adjust the desired power output level using front panel. Check reflected power is OK.

That finishes the set-up. A much more detailed explanation is available in the appropriate sections of this manual as well as additional options. You should read through it!

1.4 Quick set-up guide

Using a transmitter stand-alone with RDS encoder

This set-up uses the built-in audio limiter and stereo generator.

1. Remove the screws holding the smaller section of lid (above the power supply module) and place to one side.
2. Locate the main board on the right side of the transmitter. Locate jumper J5 right behind the BNC connectors. Move it to left position (Loop-through off).
3. Reassemble the lid back on.
4. Place a transmitter in a well ventilated space. If it's rack-mounted, leave at least 1U free above and below it for adequate cooling.
5. Connect the antenna to the RF output connector on the back of the transmitter.
6. Connect the left and right program audio signals to the XLR input connectors on the back of the transmitter.
7. Connect the Baseband/MPX output on the back of the transmitter to the MPX input of the RDS encoder.
8. Connect the MPX output of the RDS encoder to the MPX input on the back of the transmitter.
9. Plug the power cord into the power supply module on the rear panel of the transmitter.
10. Once the transmitter is operating, set the correct carrier frequency from the front panel (this can also be locked and set internally).
11. Adjust the desired power output level using front panel. Check reflected power is OK.
12. Check the documentation that came with your RDS encoder on how to set/check the proper RDS injection level.

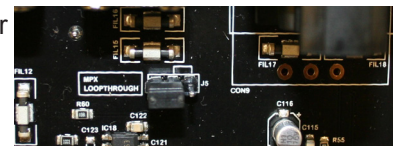

**MPX Loopthrough Jumper
in off position**

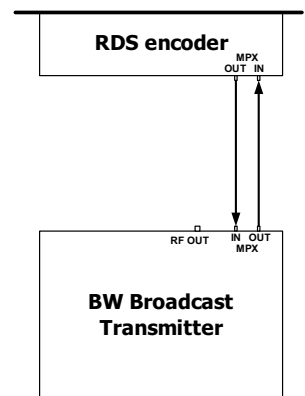

MPX connections

That finishes the set-up. A much more detailed explanation is available in the appropriate sections of this manual as well as additional options. You should read through it!

1.4 Quick set-up guide

Using a transmitter with external audio processor/stereo generator but without RDS encoder

1. Remove the screws holding the smaller section of lid (above the power supply module) and place to one side.
2. Locate the main board on the right side of the transmitter. Locate jumper J5 right behind the BNC connectors. Move it to left position (Loop-through off).
3. Reassemble the lid back on.
4. Place a transmitter in a well ventilated space. If it's rack-mounted, leave at least 1U free above and below it for adequate cooling.
5. Connect the antenna to the RF output connector on the back of the transmitter.
6. Connect the MPX output of your audio processor (or stereo generator) to the MPX input on the back of the transmitter.
7. Plug the power cord into the power supply module on the rear panel of the transmitter.
8. Once the transmitter is operating, set the correct carrier frequency from the front panel (this can also be locked and set internally).
9. Adjust the desired power output level using front panel. Check reflected power is OK.
10. Check the modulation level - if the modulation level is low, adjust the MPX output level on your audio processor (or stereo generator) and/or the MPX input level on the back of the transmitter. The maximum modulation should not exceed 75kHz.
11. Check the documentation that came with your audio processor on how to set/check the proper pilot injection level.



**MPX Loopthrough Jumper
in off position**

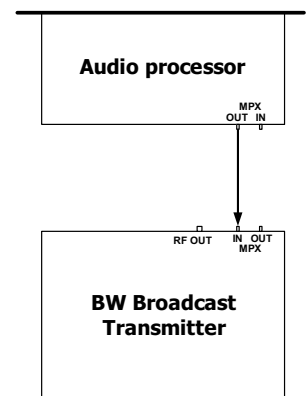

MPX connections

That finishes the set-up. A much more detailed explanation is available in the appropriate sections of this manual as well as additional options. You should read through it!

1.4 Quick set-up guide

Using a transmitter with external audio processor/stereo generator and with RDS encoder (in-line connection)

1. Remove the screws holding the smaller section of lid (above the power supply module) and place to one side.
2. Locate the main board on the right side of the transmitter. Locate jumper J5 right behind the BNC connectors. Move it to left position (Loop-through off).
3. Reassemble the lid back on.
4. Place a transmitter in a well ventilated space. If it's rack-mounted, leave at least 1U free above and below it for adequate cooling.
5. Connect the antenna to the RF output connector on the back of the transmitter.
6. Connect the MPX output of your audio processor (or stereo generator) to the MPX input of your RDS encoder.
7. Connect the MPX output of your RDS encoder to the MPX input on the back of the transmitter.
8. Plug the power cord into the power supply module on the rear panel of the transmitter.
9. Once the transmitter is operating, set the correct carrier frequency from the front panel (this can also be locked and set internally).
10. Adjust the desired power output level using front panel. Check reflected power is OK.
11. Check the modulation level - if the modulation level is low, adjust the MPX output level on your audio processor (or stereo generator), RDS encoder and/or the MPX input level on the back of the transmitter. The maximum modulation should not exceed 75kHz.
12. Check the documentation that came with your audio processor on how to set/check the proper pilot injection level.
13. Check the documentation that came with your RDS encoder on how to set/check the proper RDS injection level.

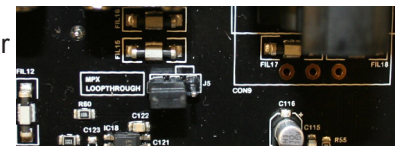

**MPX Loopthrough Jumper
in off position**

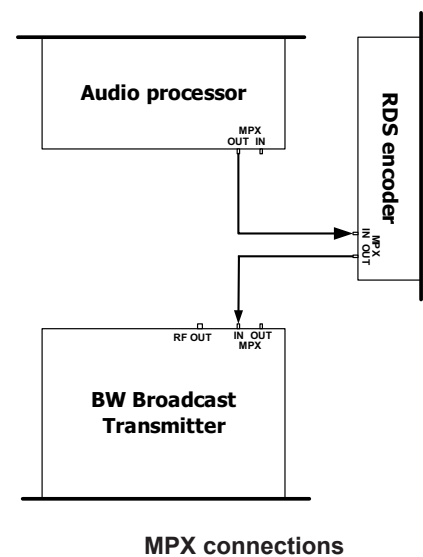

That finishes the set-up. A much more detailed explanation is available in the appropriate sections of this manual as well as additional options. You should read through it!

1.4 Quick set-up guide

Using a transmitter with external audio processor/stereo generator and with RDS encoder (sidechain connection)

This is the best connection in terms of pilot and RDS subcarrier phase synchronization and MPX spectrum cleanliness.

1. Remove the screws holding the smaller section of lid (above the power supply module) and place to one side.
2. Locate the main board on the right side of the transmitter. Locate jumper J5 right behind the BNC connectors. Move it to left position (Loop-through off).

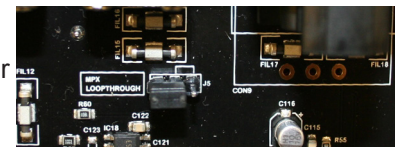

MPX Loopthrough Jumper in off position

3. Reassemble the lid back on.
4. Place a transmitter in a well ventilated space. If it's rack-mounted, leave at least 1U free above and below it for adequate cooling.
5. Connect the antenna to the RF output connector on the back of the transmitter.
6. Connect the MPX output of your audio processor (or stereo generator) to the MPX input on the back of the transmitter.
7. Connect the Pilot output of your audio processor (or stereo generator) to the Reference input on your RDS encoder.
8. Connect the MPX output of your RDS encoder to the SCA input on your audio processor.
9. Plug the power cord into the power supply module on the rear panel of the transmitter.
10. Once the transmitter is operating, set the correct carrier frequency from the front panel (this can also be locked and set internally).

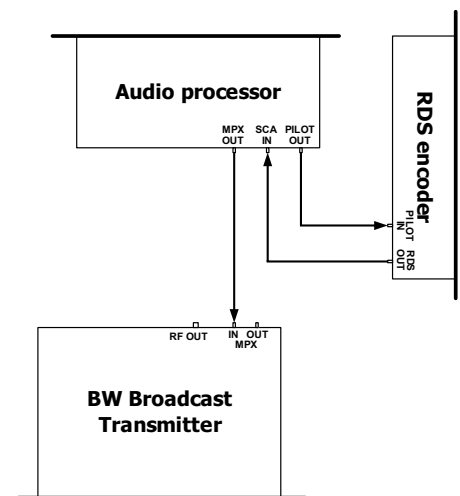

MPX connections

11. Adjust the desired power output level using front panel. Check reflected power is OK.
12. Check the modulation level - if the modulation level is low, adjust the MPX output level on your audio processor (or stereo generator) and/or the MPX input level on the back of the transmitter. The maximum modulation should not exceed 75kHz.
13. Check the documentation that came with your audio processor on how to set/check the proper pilot injection level.
14. Check the documentation that came with your RDS encoder on how to set/check the proper RDS injection level.

That finishes the set-up. A much more detailed explanation is available in the appropriate sections of this manual as well as additional options. You should read through it!

1.5 FRONT AND REAR PANELS

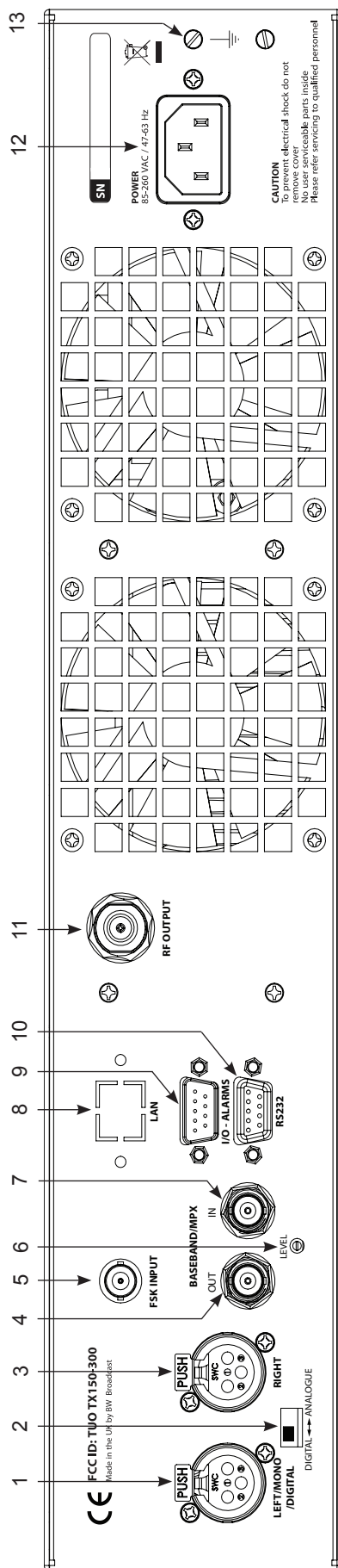
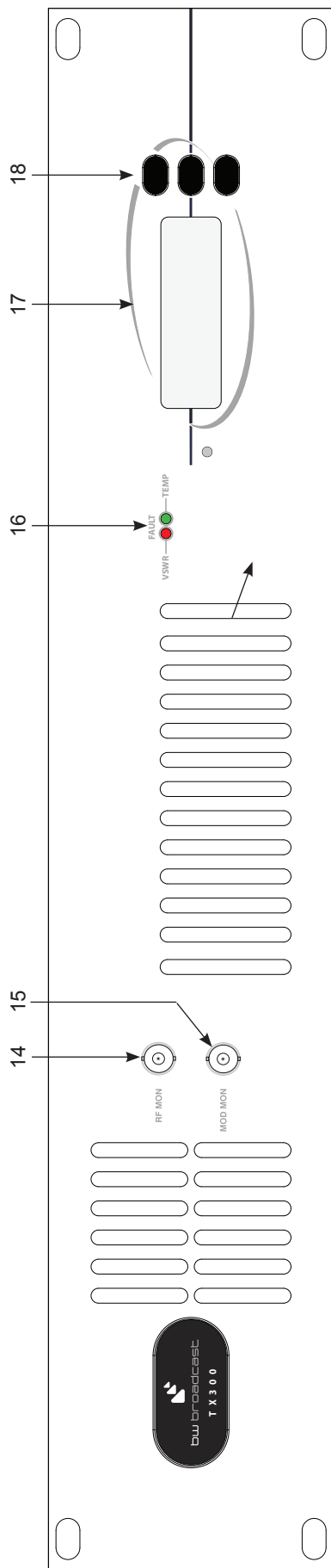

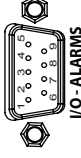
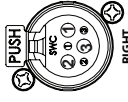
- | | |
|---|--|
| <ol style="list-style-type: none"> 1. Left audio input/Digital audio input 2. Analogue/Digital input selector 3. Right audio input 4. MPX output 5. FSK input (optional) 6. MPX level control 7. MPX input 8. LAN Socket (optional) 9. I/O + Alarms 10. RS232 11. R.F. output 12. Power socket 13. Chassis ground post 14. RF monitor output -50dBc (not suitable for | <ol style="list-style-type: none"> 15. harmonic measurements
Modulation monitor output (buffered multiplex, nominally 3V peak-to-peak for 75kHz) 16. VSWR and temperature fault LEDs 17. LCD display 18. Up / Down frequency buttons |
|---|--|
-
- | | |
|--|--|
| <ol style="list-style-type: none"> Pin 1 +18V DC 200mA Pin 2 RF Mute Pin 3 RF failure alarm (TTL) Pin 4 PLL failure alarm (TTL) Pin 5 MOD failure alarm (TTL) Pin 6 GND Pin 7 RF failure alarm (OC) Pin 8 PLL failure alarm (OC) Pin 9 MOD failure alarm (OC) | <p>I/O - Alarms D-type connector pinout:</p>  <p>I/O - ALARMS</p> |
|--|--|
-
- | | |
|--|---|
| <p>XLR Audio input connectors</p>  <p>PIN1 GND
PIN2 Hot (+)
PIN3 Cold (-)</p> | <p>harmonic measurements)
Modulation monitor output (buffered multiplex, nominally 3V peak-to-peak for 75kHz)
VSWR and temperature fault LEDs
LCD display
Up / Down frequency buttons</p> |
|--|---|

1.6 CONTROL AND MONITOR LCD

The front panel LCD graphics display has seven screens (shown below). These allow monitoring of the transmitter's R.F, audio and other parameters and the adjustment (if internally allowed) of the transmitter's frequency. You can move through the screens by pressing the NEXT button, which will display them in the following order.

Main parameter screen.

This shows together the three most important transmitter parameters. Frequency, R.F. output power and the peak deviation.

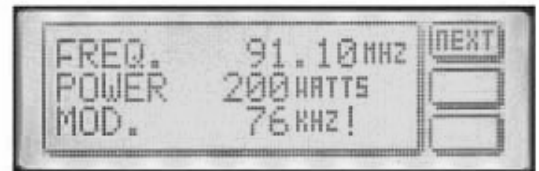

Frequency display and control

This screen will display the frequency and PLL locked condition. The up and down buttons will allow 100 kHz frequency steps from 87.5 to 108Mhz if the internal switches are set to 4440. If the frequency is set internally with the rotary switches then the up / down buttons will give a 'not allowed' message

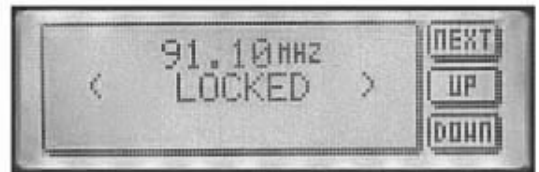

Peak deviation

This display indicates the peak and average deviation. Peak deviation is shown both numerically and as a moving single pixel wide bar. Average deviation is shown with the solid black bar. Over-deviation will display an exclamation (!)

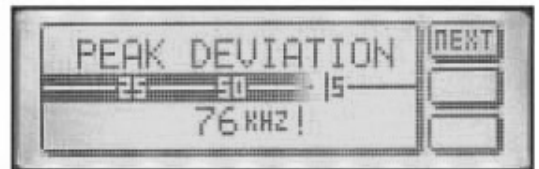

Power supply

Power amplifier voltage is shown together with the transmitter's secondary supply that feeds the exciter section. The power amplifier voltage will vary depending on set output power and the presence of any fault conditions which also cut the voltage back and with it the R.F. output.

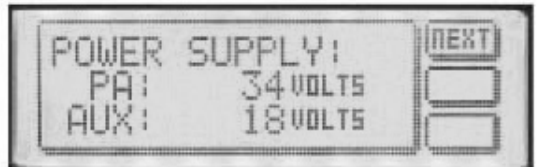

2.1 FREQUENCY SETUP

The Frequency can be set on the transmitter in one of two ways:

1. From internal direct reading decimal switches on the main board
2. From the front panel LCD display and front panel buttons.

Many radio regulatory bodies stipulate that the transmitters parameters including the frequency must not be easily changed from the front panel. To meet this requirement you will need to set the frequency internally with the dial switches.

The switches have a silkscreen diagram next to them on the board (see diagram below) clearly indicating what each switch represents.

The top dial switch represents the value selected x 10 Mhz with the exception of '0' which represents 10 so when selected would equal 100 Mhz.

The second dial switch represents the value selected x 1 Mhz.

The third dial switch represent the value selected x .1 Mhz (100 kHz)

The bottom switch represents the value selected x .0125 Mhz (12.5 kHz)

For example:

FREQ	SWITCHES (MHz)			
	X10	X1	X.1	X.0125
87.90	'8'	'7'	'9'	'0'
98.75	'9'	'8'	'7'	'4'
100.00	'0'	'0'	'0'	'0'
104.225	'0'	'4'	'2'	'2'
108.00	'0'	'8'	'0'	'0'

Frequency selection switches on main board

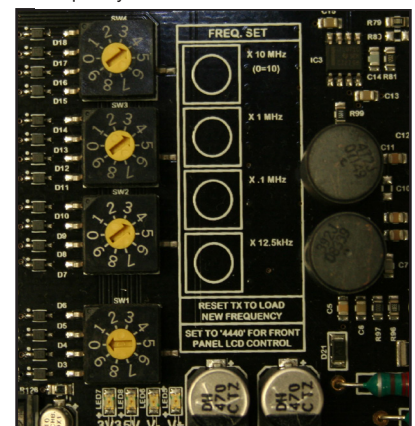

As you can see, the switches directly read the frequency with the exception of frequencies above 100 Mhz, where the top switch being set at '0' represents '10'. The X0.125 'offset' switch is only used when you want to provide a shift to the carrier of between 12.5 kHz and 112.5 kHz. Note that setting the switch on 8 or 9 will have the same effect as setting the previous switch (100 kHz) 1 position higher, as 8 represents 100 kHz on the 12.5 kHz switch. $8 \times 0.125\text{MHz} = 0.1\text{MHz} = 100\text{kHz}$

The LCD display on the front panel will display the frequency that you have set on the internal switches. If you try to adjust the frequency with the front panel up / down buttons you will get a ' NOT ALLOWED ' message appearing on the LCD display. This protects against unauthorized front panel frequency changes when the frequency has been set internally with the dial switches.

The TX will load the switch values at power up. You will need to remove the mains power to the transmitter and then reapply it if you want to change the frequency by using the direct reading switches

LCD front panel frequency selection.

If you want to control the frequency from the front panel LCD control system you will need to set the internal switches to 4440. The transmitter will pass frequency control to the LCD control system and the frequency can be moved up and down by pressing the NEXT button until the frequency menu is displayed. The other two buttons control the UP and DOWN frequency selection. PLL lock status is also displayed on this screen.



The LCD readout will only display frequencies in 100Khz steps. Any frequency offsets derived from the internal 12.5kHz offset switch will not show on the LCD. Consult a frequency counter if using offsets.

2.2 R.F. POWER SETUP

The R.F. power output from the transmitter can be controlled by an analogue potentiometer (POT) or from the front panel LCD screen or a combination of both.

ANALOGUE POWER CONTROL

If the frequency is set internally with the dial switches you will not be able to adjust the power from the LCD screen. This is to comply with regulatory body's that stipulate that the transmitter is not to have its parameters adjustable from the front panel. In this case you must use the maximum power set control to set the transmitters power. This control will give the full power range adjustment.

If the transmitter has been internally set to 4440 with the dial switches then you can also control the power from the LCD screen's R.F. power menu's up and down buttons. A "not allowed" message will be displayed to the user if the dial switches are not set to 4440

RS232 power control will over-ride the power control restrictions caused by having the frequency set internally (not set to 4440).

DIGITAL POWER CONTROL

When the power is to be controlled from the front panel the max power set POT takes on a new role of setting the maximum power of the transmitter. If you want the LCD screen to have full power range control of the transmitter you will need to ensure that the max power set control is at maximum power. Otherwise your control range may be limited. This feature enables you to limit the transmitters maximum power to a fixed level but to still allow the LCD screen to provide adjustment of the R.F. power down from that maximum power set point. This can be desirable in transmitter hire situations where you wish to govern the maximum output to a fixed level but to allow the customer (hirer of the transmitter) to run the power of the transmitter at a lower level if they so decide.

The maximum power set is positioned to the lower left of the LCD screen on some models, other models may not have the hole in the front panel and you will need to remove the lid of the transmitter to access the adjustment which will be in the same position but on the other side of the PCB. You will need a small 'tweaker style' flat-head screwdriver to adjust the pot. This control is quite delicate so try to not be too heavy handed in its adjustment.

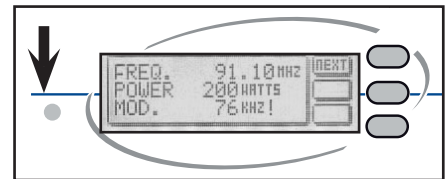

Please note that the VSWR and temperature protection circuitry will turn back the R.F. power if a fault condition exists. Make sure that you have a good VSWR (low reverse power reading) before setting the R.F. power as the removal of a fault condition may cause the R.F. power to increase.

RF POWER MUTE (analogue)

There is a pin (4) on the back panel I/O D-type that can be pulled low to mute the transmitters RF power.

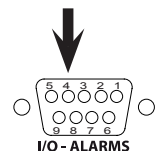

RF POWER MUTE (digital/RS232)

The transmitters RF power output can be muted via the RS232 control system. Terminal software can mute/unmute the RF power with the 'o' and 'f' commands respectively.

The windows application has a button that can toggle the RF output of the transmitter.

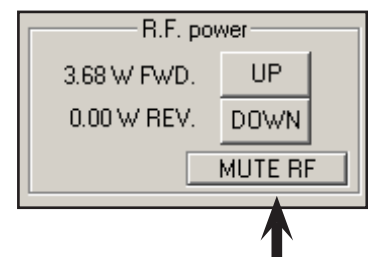

Please consult the RS232 section of this manual for more information on controlling the transmitter remotely.

2.3 ALARMS

The transmitter has three alarms that can alert the broadcaster if one of the following fails:

R.F. POWER, PLL LOCK, MODULATION

The alarms when set are available on the back panel 9-pin D-type. Each alarm has an open collector (OC) and a TTL level contact on the D-type. The alarm induced active open collectors can pull down any external signals and the TTL outputs will provide a 5 Volt indication. The alarm is also visible if any RS232 monitoring (through Windows Remote Control application or terminal software) is employed.

For the alarms to function correctly the transmitter must be left on the default menu screen. This is the screen that displays frequency, R.F. power and peak deviation. To ensure that the alarm system functions correctly the transmitter will return to the default menu screen if the LCD is left on another menu screen for more than 5 minutes.

R.F. POWER.

The R.F. power alarm will be set if the R.F. power falls below a threshold level during normal operation. This threshold is set below the normal operating lowest wattage available from the transmitter. If you require a different setting for the alarm, contact our tech dept. The alarm will only be set if the fault condition exists for sixty seconds or more. You will need to reset the transmitter to clear the alarm/s or you can do it via RS232 connection.

PLL LOCK.

The PLL lock alarm will be set if the transmitters falls out of frequency lock during normal operation. The alarm will only be set if the fault condition exists for sixty seconds or more. You will need to reset the transmitter to clear the alarm/s or you can do it via RS232 connection.

MODULATION FAILURE.

The Modulation failure alarm will be set if during normal operation the peak deviation of the transmitter drops and remains below 16 kHz. The 16 kHz alarm level allows the alarm to be set if the audio feed to the transmitter fails even if the stereo pilot internal to the transmitter is still modulating the transmitter. The alarm will only be set if the fault condition exists for sixty seconds or more. You will need to reset the transmitter to clear the alarm/s or you can do it via RS232 connection.

MORE INFO ON ALARMS

The three alarms are available on the back panel D-type connector. The pin-outs are shown on the rear panel diagram. The three alarms are available as TTL level and as open collector outputs. The TTL level outputs are active high in the event of an alarm. The open collector outputs are ON in the event of an alarm and will pull down any external levels. The open collectors can sink 100 mA MAX with an absolute maximum switched voltage of 25 volts.

The D-type connector can also supply 18 volts at 200 mA that can be used for pull-ups on the open collector alarm outputs and for your own external switching circuitry.

The RS232 interface provides the ability to reset the alarms either through Windows Remote Control application or terminal software. More info is found in the following pages of the manual.

BW Broadcast can also customise the alarm / fault software to meet the requirements of major broadcasters and networks or supply N+1 solutions. More information on this and other custom features can be obtained from our technical department.

2.4 RS232 CONTROL AND MONITORING

The TX range of transmitters can be monitored or controlled from a personal computer either locally or remotely. The Transmitters can “chat” either by a windows application or via a standard serial terminal program. The windows application is the more versatile option and is to be preferred but the ability to use a terminal program can prove useful in the absence of the windows application or a computer that runs windows. The front panel should not be used while the remote control is connected.

2.4.2 Windows application

The latest version of Windows Remote Control application can be downloaded from:
<http://www.bwbroadcast.com>

Installation

After downloading just click on the .msi file to run the set up program. The set up will place icons in both the Windows start menu and on your desktop. Simply run the program by clicking on icon from either location.

Running the application

When started the application will resemble the picture to the right.

The application can connect to any COM port currently available on your computer that is running the application. Connect a serial cable between the RS232 connector on the rear of the transmitter and one of your computers COM ports. If you are using a codec or other STL device then you may be able to connect that device in line to act as part of the serial link.

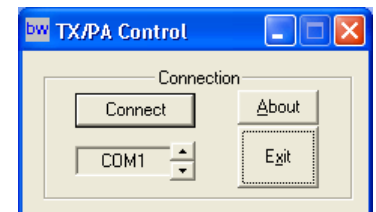

Remote Control Application startup screen

Selected the COM port you want to use and then click the Connect button.

If the application is able to connect to the transmitter then you will be presented with a screen similar to the one above. Once connected you should be able to monitor all the parameters of the transmitter as well as being able to mute the R.F., change the frequency, change the R.F. power and reset any alarm flags that have been set.

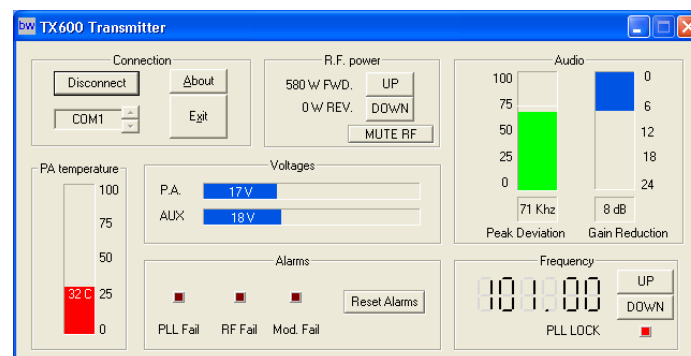

Remote Control Application

2.4.3 Terminal control of the transmitter

Installation

Please see the instructions for your terminal software package to find out how to connect to a remote serial

device. The transmitter is internally set to communicate at 9600 bps, no parity with 1 stop bit and hardware flow control. This is commonly known as 9600 8N1. If your using Windows then you can use the pre-bundled terminal program “Hyper-terminal”. This is located in the Programs -> Accessories -> Communications folder accessible from the Start menu. Select direct to COM port x where x is the com port that the transmitter is connected to. You will be presented with a dialog box like the one shown to the right. Select 9600, 8, none ,1 with hardware flow control and then click OK.

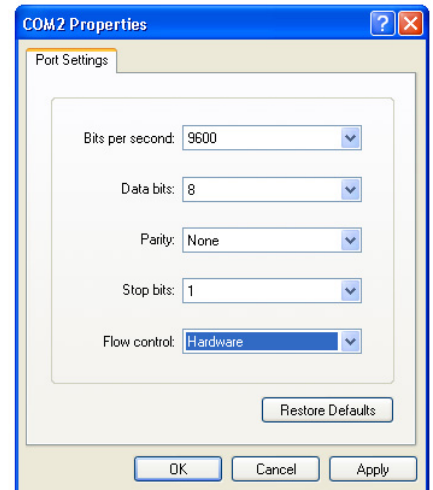

Hyper Terminal connection

If you are using another terminal program then you may need to consult the documentation for that software, but it should be pretty much straight forward.

Operation

The transmitter will respond to certain key presses and each one has a certain function. See the list below for details of what key to press for each function.

The most important key press is the ‘Enter’ key. This will need to be pushed as soon as you connect to the transmitter so you can get the transmitter to refresh your terminal window with the transmitters status and parameters.

The transmitter won’t respond to any of the other key presses until it detects the ‘Enter’ key is pressed. Once the Enter key is pressed the transmitter will listen out for other key presses for 60 seconds. This Initial ‘Enter’ key validation and time window is a safety feature to prevent the transmitter from detecting an erroneous key press such as R.F. mute and causing a service affecting problem.

After performing a function you may need to press the ‘Enter’ key to see a response to your function. For example, If you pressed ‘o’ for R.F. Mute you would not see the effect of the R.F. power change until you refreshed the screen again because the terminal window would still be showing the transmitters R.F. power from the previous ‘Enter’ (screen refresh) command, prior to you performing the R.F. mute command.

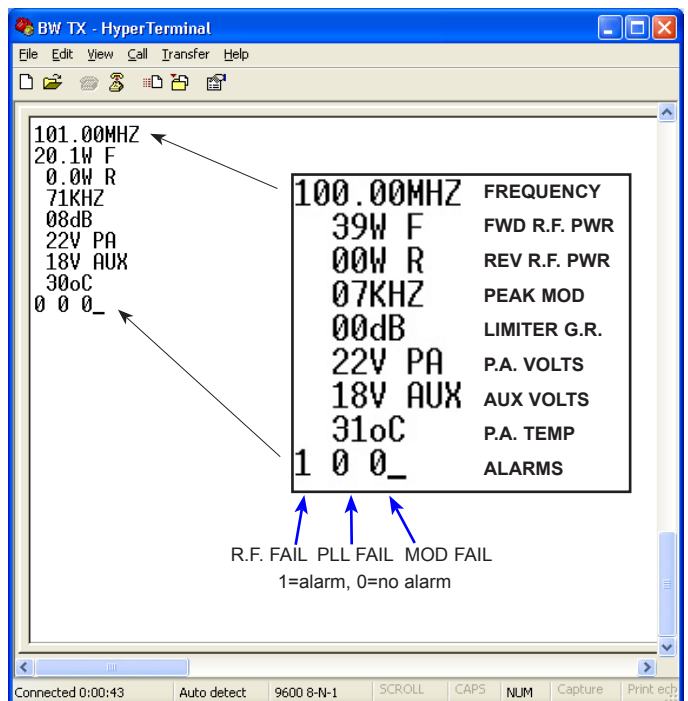

Hyper Terminal window

The frequency change key’s will perform an automatic screen refresh on there execution but the other keys will require a refresh command to be sent to the transmitter for you to visibly be able to see the effect of your command. In some circumstances you may need to press the refresh screen key several times in order to see what’s happening. Take the R.F. mute function again as an example. You press the R.F. mute key (‘o’) and then press refresh screen key (‘ENTER’) to get a status update. The transmitters power control circuitry may not have had time to turn the R.F. power down into full R.F. mute by the time it has sent back to you the status requested by the refresh screen command. It does no harm to wait a second or two before asking for a refresh screen or by asking for several refresh screens by pressing the ‘Enter’ key a few times in succession.

KEY	COMMAND
1	Frequency up
2	Frequency down
3	R.F. power up
4	R.F. power down
5	reserved
6	Reset alarms (all to 0 / off)
o	Mute R.F.
f	Unmute R.F.
ENTER	Refresh screen

2.5 MODES OF OPERATION

The transmitter is fully configurable and can be set up to support various modes of operation. The mode of operation is set by the configuration of the internal jumpers.

This chapter provides a guide to the various jumpers, followed by a brief description of the main modes of operation. The advanced setup procedure pages that follow provide a little more information on each mode as well as providing some information on setting the equipment up accurately if you have access to some test equipment.

2.51 A guide to the hardware settings

Main combo board

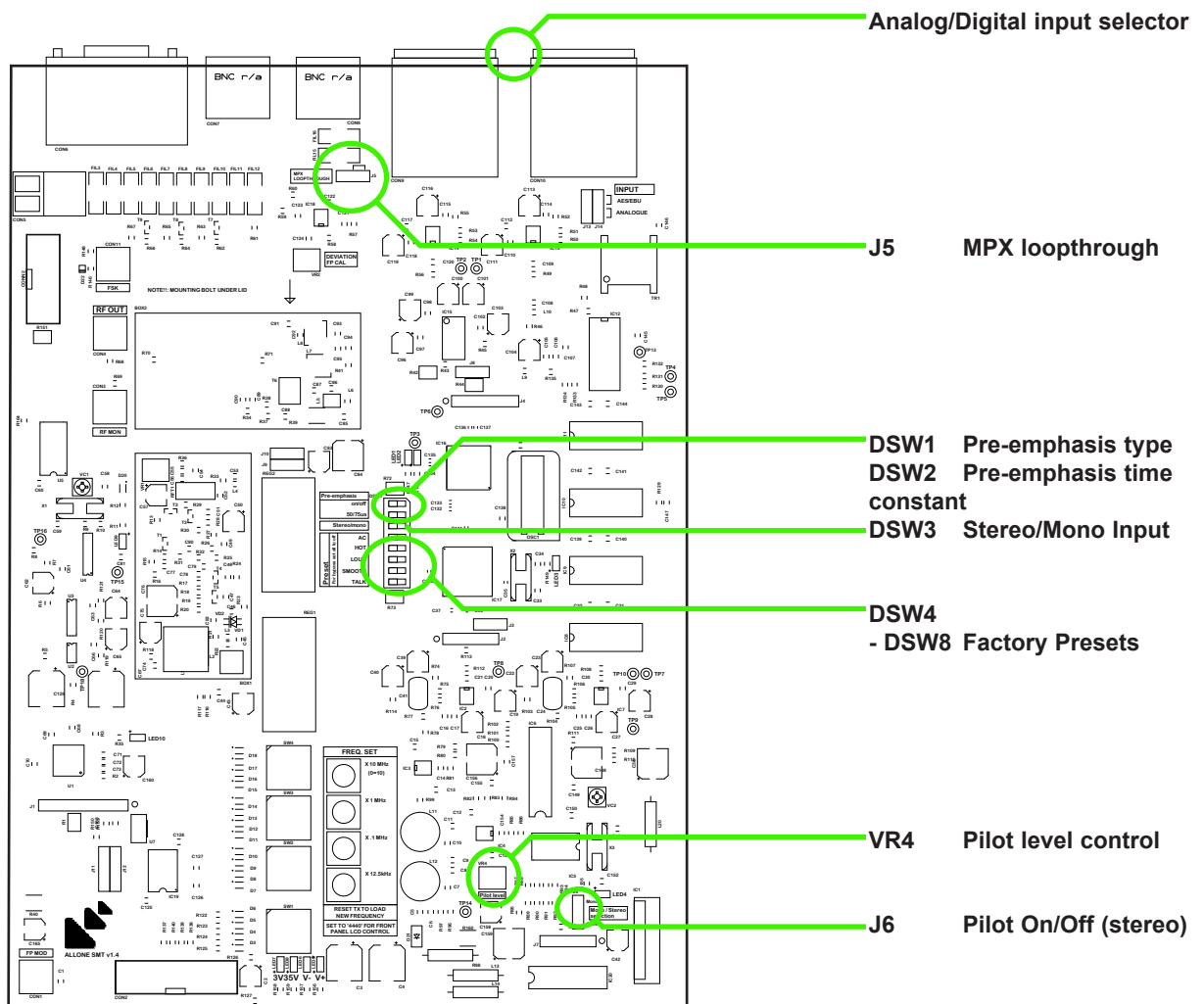

The board leaves the factory with default settings which should be suitable for most locations and requirements. Nevertheless, it is worth familiarizing yourself with all the options available, and checking that the settings are appropriate, as part of the installation process.

Analog/Digital input selector

The default position is analog.

Setting this to digital allows a digital (AES/EBU) input to be fed to the left XLR input.

Jumper 5: MPX loophrough

The default position is ON (right).

This is where you want the audio left and right XLR sockets on the back of the board to be the signal source, duly limited and stereo coded internally. Only when you want to use the rear BNC socket for a complete multiplex (MPX) input for the broadcast should you change the position of this link.

If the link is in the OFF position, only signals from an external encoder or processor will be accepted, unless the internal coder has been 'loop-throughed' (see later).

DIP switch 1: Pre-emphasis on / off

DIP switch 2: Pre-emphasis 50 / 75 μ s

The default position is 50 μ s (75 μ s USA/Japan).

What is pre-emphasis?

Pre-emphasis is the treble boost that must be applied to all FM broadcasts to compensate for the treble cut (de-emphasis) present in every receiver. The aim of this process is to reduce noise in the broadcast path without degrading the audio.

The precise nature of the treble boost is defined by a time-constant in microseconds, which describes the resistor/capacitor network that will produce the appropriate 6dB per octave treble boost curve.

There are two different standards in use worldwide.

In Europe and Africa, the standard is normally 50 μ s. This represents a lift of about 3dB at 3 kHz, and 10dB at 10 kHz. In the Americas, and in Japan, more boost is in use with a network of 75 μ s, about 3dB up at 2 kHz.

The effects of pre-emphasis

The absence of any pre-emphasis will result in a broadcast sounding noticeably lacking in treble. Applying 50 μ s pre-emphasis will correct the situation in European receivers (75 μ s in US/Japan). If you apply 75 μ s pre-emphasis when 50 is called for, the received sound will have some 3dB shelved treble boost above 3kHz. This is undesirable. Conversely, if you only apply 50 where 75 is required, there will be 3dB treble loss, which is also undesirable. You should not have to change the pre-emphasis setting from 50 to 75 or back unless you are relocating the installation abroad where the standard is different.

However, whenever pre-emphasis is deliberately applied to your audio at some point before it enters the XLR sockets on the back of the board, by an external processor for example, then you must set the pre-emphasis to off, because pre-emphasis must only be applied once. *Double pre-emphasis must be avoided* because it will make a signal sound far too bright and topky.

DIP switch 3: Stereo / Mono

The default position is stereo.

When the board is operating in mono, this should be set to mono. This ensures that when the board is operating in mono, no stereo information is broadcast, and that a mono drive to either left or right inputs, or a stereo input applied simultaneously to L and R inputs, will produce proper summed mono operation and no spurious 38kHz signals.

DIP switches 4-8: Factory Presets

DSW4 - 8 off Preset Bypass
All presets bypassed. For use with an external processor.

DSW4 AC (Factory Default)
A nice balance for lighter formats where loudness is not everything. A good all-rounder and ideal starting point.

DSW5 HOT
Nice balance of bass and treble give the preset punch without sacrificing clarity.

DSW5 LOUD
A more competitive preset for crowded markets where loudness is important.

DSW5 SMOOTH
Controlled bass and highs with this preset will make your sound roll. Suits a variety of formats

DSW7 TALK
Higher gating thresholds and slower decays help to prevent ambience noise swelling. Perfect for talk format stations.

It's important to listen to and compare the options while passing a representative selection of typical programme material through the board. This will help you establish which sound you prefer.

Jumper 6: Pilot On/Off (stereo)

The default position is STEREO, pilot tone on.

This option allows you to remove or restore the stereo pilot tone, at a frequency of 19 kHz, normally sitting at a level between 8 and 10% of total deviation.

It is this tone which alerts stereo FM receivers to the need to switch on their stereo decoders. The presence of a pilot tone is all that is required for the 'stereo' beacon to light on a receiver. If no 19kHz tone is received, the receiver will operate in mono. It will not decode any L-R information modulated on the 38 kHz subcarrier, *even when it is still present.*

To make sure that no 38 kHz energy is generated during mono operation even from stereo inputs, set DIP switch 3 to mono. This jumper does not affect the mono/stereo status of externally-coded MPX inputs.

Modes of operation**Multiplex / broadband input.**

The Internal stereo encoder and audio limiter are not used. Wideband modulation is fed into the rear panel BNC multiplex input socket. Allows external processors, encoders and rebroadcast receivers to be plugged straight into the transmitter.

JUMPERS. J5 (OFF), J6 (NA), DSW1-8 (NA)

Stereo with no processing presets.

Left and Right audio are fed to the back panel balanced inputs and are pre-emphasized, peak limited, filtered and then fed to the internal stereo encoder for multiplex generation. This mode can be used when you are using an external processor to provide the correct sound. The multiplex signal is then fed through to the exciter module and to the back panel multiplex output BNC socket. See loopthrough mode below *

JUMPERS. J5 (ON), J6 (STEREO), DSW1 (ON / OFF), DSW2 (50 / 75), DSW3 (STEREO), DSW4-8 (OFF)

Stereo with processing preset. (Factory Setting)

As the above stereo with no processing mode except the internal processor is used. See loophrough below *

AC (Default)	JUMPERS. J5 (ON), J6 (STEREO), DSW1 (ON / OFF), DSW2 (50 / 75), DSW3 (STEREO), DSW4 (ON), DSW5-8 (OFF)
HOT	JUMPERS. J5 (ON), J6 (STEREO), DSW1 (ON / OFF), DSW2 (50 / 75), DSW3 (STEREO), DSW4 (OFF), DSW5 (ON), DSW5-8 (OFF)
LOUD	JUMPERS. J5 (ON), J6 (STEREO), DSW1 (ON / OFF), DSW2 (50 / 75), DSW3 (STEREO), DSW4-5 (OFF), DSW6 (ON), DSW7-8 (OFF)
SMOOTH	JUMPERS. J5 (ON), J6 (STEREO), DSW1 (ON / OFF), DSW2 (50 / 75), DSW3 (STEREO), DSW4-6 (OFF), DSW7 (ON), DSW8 (OFF)
TALK	JUMPERS. J5 (ON), J6 (STEREO), DSW1 (ON / OFF), DSW2 (50 / 75), DSW3 (STEREO), DSW4-7 (OFF), DSW8 (ON)

Mono from two independent channels.

Essentially the same as the stereo mode except the stereo pilot is disabled which will enable receivers to receive you in mono. See loophrough mode below *

JUMPERS. J5 (ON), J6 (MONO), DSW1 (ON / OFF), DSW2 (50 / 75), DSW3 (MONO), DSW4-8 (OFF / ON)

Mono from one channel input.

Essentially the same as the stereo mode except the stereo pilot is disabled which will enable receivers to receive you in mono. You can provide one audio feed to the transmitter via the left balanced input. See loophrough mode below *

JUMPERS. J5 (ON), J6 (MONO), DSW1 (ON / OFF), DSW2 (50 / 75), DSW3 (MONO), DSW4-8 (OFF / ON)

*** Loophrough mode**

The transmitter has been provided with a multiplex output socket to present the output of the internal audio stages to the outside world. This allows you to connect the signal from the internal limiter and stereo encoder to an external piece of equipment before being injected back into the transmitter via the multiplex input socket.

The most common application is for RDS encoders which nearly always have a loophrough connection for this purpose. Other applications include SCA generators and composite clippers. You will need to set the internal jumper to off for external loophrough. This is to stop the internal stereo encoder's multiplex output signal from being fed to the exciter section internally.

More information on loophrough setup is provided at the end of the advanced setup procedure section.

ADVANCED SETUP PROCEDURE

The front panel LCD metering is accurate enough to set up the transmitter in the absence of external test equipment. If you have access to a modulation meter and RF power meter then substitute those for references to the relevant LCD display menu.

You will most likely need the following pieces of test equipment:
 Audio signal generator capable of -10dbu to +10dbu
 Voltmeter

2.52 Multiplex input only.

Open the lid of the transmitter and make sure that jumper J5 on the main board is configured so that MPX Loophrough is OFF. This makes sure that the internal stereo encoder is not connected through to the modulator. Connect your wide-band audio source (processor, coder or rebroadcast receiver) to the multiplex input on the back panel. Setup your external equipment for its correct output level making sure that it falls into the range of -6 to +10 dbu. Adjust the multiplex input level control on the back panel for a peak deviation of +/- 75kHz. The peak deviation can be shown on the LCD system.

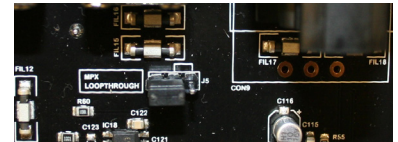

**MPX Loophrough Jumper
in off position**

The factory setting for the multiplex input level is +6dBu. This corresponds to the output level of our internal stereo encoder module. We recommend feeding this level input to the multiplex input socket if it is available from the external equipment.

2.53 Stereo.

The limiter can be disabled internally if you do not require it. This effectively allows any audio input signals straight through to the stereo encoder unaltered. You may wish to disable the limiter when you have an external processor or limiter that may be of a higher performance than the internal limiter in this transmitter. You can still have the limiter active even with external limiters in operation. We leave that up to you. For safety purposes you may wish to leave the clippers on the limiter and the 15 kHz filters in to provide extra protection when you are unsure of the peak output characteristics of the external piece of equipment. When you know that the piece of audio processing equipment is band-limited to 15 kHz and peak limited you can leave out the clippers safe in the assumption that the external processor will be able to handle the level control completely.

Advanced setup procedure.

1. Firstly make sure that the exciter is set to your chosen operating frequency. If you have not already done so then remove the top cover from the transmitter.
2. Connect the transmitter to a dummy load.
3. Turn on the transmitter and within 10 seconds it should lock to frequency.
4. If your audio feed has gone through an external processor prior to this transmitter then check to see if that unit has pre-emphasis capability and if it is switched on. If it has pre-emphasis and it is enabled then you should set the transmitter pre-emphasis DIP switch, set to off to ensure that only one set of pre-emphasis has been applied throughout the broadcast chain. Otherwise, switch it to on and set DIP switch 2 to the correct setting for your region, 75µs for the Americas and Japan and 50µs for the rest of the world. Turn the pre-emphasis off for now by setting DIP switch 1 to the right. Make sure the loophole jumper J5 is switched to loophole and DIP switch 3 is set to stereo. Disable the stereo pilot by setting jumper J6 to mono.

These settings will allow any audio straight through the limiter and into the stereo encoder without any form of level control apart from the peak level clippers, so we can set the system internal levels correctly.

5. Connect an audio source to both channels and apply a 400Hz tone with a level of +6dBu.

6. Work out the the pilot level you intend to use. It is usually between 8 and 10 percent of the modulation with 9 percent being standard in most countries. 9 percent corresponds to 6.75 kHz deviation so for a total peak deviation of 75 kHz (the industry standard for 100 percent modulation) we need to adjust the multiplex level for a peak deviation of 68.25 kHz (91 percent modulation). This corresponds to the total minus the intended pilot level that we will re-introduce in a moment. We recommend further backing off the deviation by 4 % which equates to 3 kHz deviation. This 4 % acts as a guard-band for any small overshoots that may occur in the limiter and the stereo encoder filters. You should at this point with your tones applied have a peak deviation of 75 kHz - 6.75kHz (or intended pilot level) - 3 kHz = 65.25kHz. If you have not already done so, adjust the multiplex input level on the back panel to this level. If you are using the LCD display metering then 65 kHz would be an acceptable setting.
8. Re-instate the pilot by setting jumper J6 to STEREO. Now adjust the pilot level control VR4 for a peak deviation of 75kHz peak deviation (100 percent modulation)

The transmitter should now have the total multiplex and the pilot setup at the correct level.

9. Connect your studio feed to the transmitter. Turn the power off to the transmitter, connect your external antenna, reconnect the power and your on the air!
10. Monitor your total peak deviation with your real world audio material and check with the deviation display that your peak deviation does not exceed 75 kHz. If you have set up the transmitter as per the instructions in this section then you should be within 1 kHz or so of this figure. If your deviation does exceed 75 kHz then adjust the back panel multiplex control to keep your maximum deviation at 75 kHz.

2.54 Mono

Mono from one channel input: You can provide one audio feed to the transmitter via the left balanced input. This has the advantage of supplying two exact audio signals to the stereo encoder section that will in turn cancel the stereo subcarrier leaving only a pure mono signal with content falling to zero above 15 kHz.

Mono from two independent channels: A stereo feed can be supplied to the transmitter's left and right inputs. If DIP switch 3 is set to mono these will be summer to mono, ensuring the subcarrier content is kept to a minimum. The absence of the pilot will force tuners to decode the broadcast in mono.

Advanced setup procedure.

1. Firstly make sure that the exciter is set to your chosen operating frequency. If you have not already done so then remove the top cover from the transmitter.
2. Connect the transmitter to a dummy load.
3. Turn on the transmitter and within 10 seconds it should lock to frequency.
4. Turn the pre-emphasis off for now by setting DIP switch 1 to the right. Make sure the loopthrough jumper J5 is switched to loopthrough. Set DIP switch 3 to mono and disable the stereo pilot by setting jumper J6 to mono.
5. Connect an audio source to both channels and apply a 400Hz tone with a level of +6 dbu
6. Adjust the multiplex gain control on the back panel for a peak deviation of 72 kHz. This allows a 3 kHz guard-band for slight overshoots that may occur in limiter and filters inside the system.
7. If your audio feed has gone through an external processor prior to this transmitter then check to see if that unit has pre-emphasis capability and if it is switched on. If it has pre-emphasis and it is enabled then you should leave the pre-emphasis DIP switch, set to off to ensure that only one set of pre-emphasis has been applied throughout the broadcast chain. Otherwise, switch it back to on and set DIP switch 2 to the correct setting for your region, 75µs for the Americas and Japan and 50µs for the rest of the world.

8. Connect as before. Turn the power off to the transmitter, connect your external antenna , reconnect your power and your on the air!

10. Monitor your total peak deviation with your real world audio material and check with the deviation display that your peak deviation does not exceed 75 kHz. If you have set up the transmitter as per the instructions in this section then you should be within 1 kHz or so of this figure. If your deviation does exceed 75 kHz then adjust the back panel multiplex control to keep your maximum deviation at 75 kHz.

2.6 OTHER SETUP CONSIDERATIONS

LOOPTHROUGH

The rear panel BNC sockets provide an easy interface to the multiplex path. You can insert an external piece of equipment between the multiplex output of the internal stereo encoder and the modulator section.

To connect an external piece of equipment consult the external equipments documentation. It should be as easy as configuring the transmitter as per normal and then simply setting the internal Loophrough jumper to OFF and taking the multiplex output to the input of the external equipment and the output of the external equipment back into the multiplex input socket. If the external equipment is not unity gain you may have to readjust the multiplex input gain slightly to take account for any gain differences. Most loophrough designed equipment is unity gain to make setup and use as simple as possible.

FREQUENCY FINE TUNE (WARNING, ADVANCED TECHNICIANS ONLY)

While the frequency is controlled by the phase locked loop system, the stability is governed by the stability of the reference. A quartz crystal is used for the reference for its high stability however component ageing can affect the frequency slightly over time. The frequency can be finely adjusted via VC1. This provides a small adjustment of the VCO frequency when locked. This will have been adjusted at factory to the correct setting and the transmitter should remain within 1kHz of the channel required. If however the frequency does move off slightly due to component ageing then you can adjust VC1 to trim the unmodulated carrier back onto channel. You will need a frequency counter to monitor the output frequency of the un modulated transmitter when adjusting VC1.

LCD SYSTEM METERING ACCURACY

DISPLAY	Measurement	Accuracy
POWER SUPPLY	Volts	+/-1 Volt
TEMPERATURE	Degrees Centigrade	+/-1 Degree
PEAK DEVIATION	kHz	+/-1 kHz
RF POWER	Watts	5 %

3.1 SPECIFICATIONS

RF

Power	15W - 150W (TX150) 15W - 300W (TX300)
Connector	N-type 50 Ohm
Harmonics	better than 82 dBc
Spurious	< -90 dBc
Frequency range	87.5 - 108 MHz
Frequency steps	100 kHz from LCD or 12.5 kHz from internal switches
Frequency selection	Internal switches or LCD system
Frequency control type	Dual speed phase locked loop
Frequency stability	< +/- 500 Hz (fine adjustment available)
MPX input	BNC
MPX input level	MPX input level -10 dB to +10 dB (adjustable)
MPX input response	MPX input response +/- 0.3 dB, 5 Hz to 100 kHz
Modulation	Direct frequency modulation
Synchronous AM Noise	0.31% (at normal deviation)
Asynchronous AM Noise	0.18% (at centre frequency of 97.7MHz)

STEREO

Subcarrier generation	Microprocessor generated 8x over-sampled
Pilot	19 kHz +/- 1 Hz (adjustable)
Pilot generation	Microprocessor generated 16x over-sampled
Output level (BNC)	(BNC) 0dB
15 kHz filtering	> 40dB at 19 kHz
Spurious	
> 80 kHz	> -60dBr
>160 kHz	> -80dBr
Stereo separation	> 55dB (20Hz-15kHz)

DSP LIMITER

Audio input levels	-10 to +24dBu (AGC) +8dBu (Bypass)
Analogue input connectors	XLR balanced (RF shielded)
Digital input connectors	XLR balanced (RF shielded)
Digital sampling rate	32-96 kHz
Input CMRR	> 60dB
Frequency response	20 Hz to 15 kHz +/- 0.5dB
Input impedance	10 kOhm
Pre-emphasis	50 µs, 75 µs and 0 µs (off)
Process modes	Bypass, AC, Hot, Loud, Smooth, Talk

OTHER

Control system	3 buttons, 122x32 graphics display
External control/monitor	I/O Alarms D9-type Male; RS232 D9-Type Female
Size	482mm x89mm x 422mm
Weight	6.9 kg
Voltage input	110 - 260 VAC
Current input	110VAC - 4A / 220VAC - 2A
Power connector	IEC, FUSED and switchable
Switched mode approvals	UL / TUV / CE

3.2 CIRCUIT DESCRIPTION

The transmitter consists of three main circuit boards, two power supply modules and the associated wiring and connectors. The power supplies are fully approved modules and won't be discussed electrically except for the connections to the other boards where appropriate.

The three PCB's previously mentioned are the combo board, the power control board and the control / LCD board. The wiring and connection between the boards can be seen in the internal case diagram.

The combo board contains

1. DSP Audio limiter with pre-emphasis capability
2. High spec over-sampled digital stereo encoder
3. High spec low distortion PLL exciter
4. Power supply circuitry to supply various voltages to the different sections
5. A logic / control section to interface to external equipment
6. Control connections to the LCD control board

The Power control board contains

1. Low pass harmonic filter
2. VSWR bridge / coupler and power sniff circuitry

The Control / LCD board contains

1. A 122x32 LCD graphics display
2. Three front panel buttons for LCD control
3. Power control adjustment and transmitter fault / protection circuitry
4. An 8 bit microcontroller to control all the LCD functions, metering and alarm monitoring

We will describe the electrical workings of the transmitter from the audio input through to the RF output and will attempt to explain how the three boards tie together and form the complete unit.

We will start at the audio input sockets on the back panel which are part of the combo board.

3.21 COMBO BOARD

Audio limiter description

Left and right audio signals are applied to balanced input XLR sockets on the back panel. The balanced audio signals are fed to IC14 and IC13 which are configured as differential amplifiers to convert the balanced inputs to unbalanced for the rest of the limiters circuitry. The output from the differential op-amps feed an oversampled ADC (IC15). The digital input feeds into an AES/EBU decoder chip (IC12) with built-in SRC via an isolating transformer (TR1). The backpanel input source switch selects which input is fed into the four DSPs (IC8-IC11). Following the digital signal processing the DAC (IC15) returns the signal to the analog domain in preparation for the stereo encoding.

Stereo encoder description

The stereo encoder section is based around a high speed switch which is used to generate the multiplex at 38 kHz. The switch is controlled by microcontroller IC5 which supplies the timing signals to the switch at 304 kHz. The high speed enables an over-sampled 38kHz subcarrier to be generated that is rock steady and spectrally clean. As the signal is generated digitally no adjustments or setups are required for the encoder. The only adjustments on the encoder section are the stereo/mono control and the level of the stereo subcarrier. The 19kHz pilot tone is also generated by the microcontroller and because of this the stereo separation is excellent due to the perfect timing between the pilot and the subcarrier. The 19 kHz pilot is also generated by over-sampling techniques to produce a very low distortion pilot tone.

The audio from the DAC is buffered through IC2 and IC7. These buffer op-amps drive into the analogue switches (IC6). The switches are controlled by the microcontroller IC5 and the output from the switches feed into three resistors R82,83,84 to provide a D/A type function producing the multiplex signal. The resistors are carefully chosen to provide sine weighting for the reconstruction, which keeps the lower order harmonic content down to

almost zero. These three resistors are combined in virtual earth mixer op-amp IC4. The stereo pilot tone emerges from the microcontroller as a 4 bit word which has sine weighting applied to it by resistors R87 to R94. At this point, apart from 19 kHz, the pilot has no significant energy below 304 kHz. The pilot is fed through VR4 for adjustment of the pilot level before being combined with the subcarrier at the virtual earth mixer op-amp IC4. The complete stereo multiplex signal emerges from IC4 and is fed into a low-pass filter formed by L11,L12 and C7-C11. This filter removes any high frequency products due to the sample rate. The filter is buffered by output op-amp IC3 which also provides a fixed output level of +6dBu, which is fed to the multiplex output BNC socket on the back panel, as well as to one side of the loopthrough jumper J5.

Exciter description

The principal frequency determining elements are inductor L1 and varicap diode VD1. These components, together with transistors T4 and T5, form a cascade oscillator whose output is then buffered and amplified by RF transistor T3. The RF output from T3 is impedance matched to the base of P.A. transistor T6 by RFT1, a 4 to 1 matching transformer. The nominal 5W power output from P.A. transistor T6 is impedance matched by coils L7 and L8 and associated capacitors C87, C92, C93 and C95 to the 50 ohm output socket CON4. A coaxial cable carries the RF output from this socket to the RF input connector on the main power amplifier PCB.

The PLL circuit is primarily U3 which is a serially programmable PLL chip. The microcontroller U1 reads the dial switches at power up and outputs a serial code to the PLL chip in a format that determines the output frequency that the PLL will lock the transmitter to. If the microcontroller detects that the switches are set to 4440 then the microcontroller will talk to the microcontroller on the control / LCD board to request the LCD display control system stored frequency. The PLL chip delivers raw control pulses to the loop filter built around op-amp U2. The loop filter is a low-pass filter that takes the raw rectangular differential outputs from the PLL chip and creates a DC voltage to apply to the frequency determining component, varicap diode VD1. The main time constant in the loop filter is formed by resistor R4 driving C67 and R5 driving C129. The high resistance of R4 and R5 allows slow charging of C67 and C129 from the PLL chip. The DC voltage derived from the output of the op-amp will be slow to change in response to the raw PLL pulses due to the slow charging of those capacitors. This slow DC voltage change is converted to slow frequency change by the varicap diode. U3 is an analogue switch that shorts out the two high resistance resistors in the loop filter to allow faster charging of C67 and C129, and so, a faster change of the output DC voltage from the filter. This faster changing voltage can allow the transmitter to get on frequency faster. When the transmitter is on frequency the analogue switch stops shorting out the high resistance resistors and the slow loop takes control, which greatly improves the audio response of the transmitter. The microcontroller U1 determines when to switch the analogue switch in and out by reading the lock detect signals from the PLL chip. The microcontroller can also use this information to switch off transistor T3 with open collector configured T2 which mutes the RF output when the transmitter is out of lock. LED9 provides visual indication of the PLL locked condition. The front panel control system will also display the locked condition when in the frequency display screen.

Audio is fed into the modulation input of the exciter from external multiplex input connector CON7 which is a BNC type or from the internal stereo encoder section by having jumper J5 set to loopthrough. The modulation level can be adjusted from the back panel by the adjustment of variable resistor VR3 which is in the feedback loop of op-amp IC18. The output of the op-amp feeds the modulation element, varicap diode VD1, via potential divider R22 and R23.

CON2 provides an interface to the control / LCD board. This ribbon cable interface provides connections for the alarm signals to the back panel D-type from the microcontroller on the LCD board together with connections for the modulation level and a serial interface which provides frequency and status information between the PLL microcontroller on the combo board and the main system microcontroller on the LCD board.

3.22 LCD CONTROL BOARD

The LCD control board is the heart of the transmitter. The board contains an eight bit microcontroller, LCD display, a voltage regulator and a dual op-amp together with a few passive components.

CON1 provides a 10 way interface to the power amplifier board and its sensors. Some of the connections of CON1 are routed around to the power supply modules. CON2 provides a 16 way interface to the combo board providing power to the combo board as well as routing signals to the back panel D-type sockets for alarms/RS232 and returning modulation to the main microcontroller.

The voltage regulator REG1 and decoupling capacitors C1 and C2 takes the 18 volt auxillary supply from CON1 and regulate it down to 5 volts for the microcontroller and LCD circuitry. The microcontroller is a 40 pin 8 bit type running at 8 MHz. The microcontroller has several ports that have various functions and connect to external components.

PORTA (6 bits) is primarily used for the analogue voltage inputs. Bit 1 the modulation, Bit 2 the AUX volts and Bit 3 the Fwd RF power. Bit 4 is not used and bit 5 of PORTA has a control connection to the LCD display.

PORTB (8 bits) has a few different functions. Bits 7,6 and 3 of the port are the alarm signal outputs and are routed off via CON2 to the D-type on the back of the combo board. Bit's 5,4 and 2 are connected to the front panel buttons to allow navigation of the LCD functions. Bits 1 and 0 provide a 2 wire interface to the PLL microcontroller on the combo board.

PORTC (8 bits) bits 0 and 1 are used to write information to the LCD display. Bit 2 is the pulse width modulator output (PWM) and connects into unity gain DC amplifier op-amp IC2A. The voltage generated by the PWM is set by the software in the microcontroller. This PWM level is then fed through potentiometer VR2 and smoothed by C13 before being buffered by the aforementioned op-amp. PORTC bits 3-5 are not used. Bit's 6 and 7 of PORTC are used by the UART inside the microcontroller. These pins are RXD and TXD for the RS232 interface. They are routed via CON2 to the back panel D-type.

PORTD's 8 bit's are interfaced to the 8 bit data bus of the LCD display. The data byte on PORTD can be latched into the LCD display by the LCD control bits on PORTC.

PORTE (3 bits) has the remaining A/D inputs. Bit 0 is the PA volts, Bit 1 is the Rev RF power and bit 2 is for the PA temperature.

The microcontrollers software reads all the analogue voltages, converts and displays them where necessary and outputs alarm signals in the event of a transmitter error. There are various passive components associated with IC1. Each A/D port has input current limiting resistors R1-11 and decoupling capacitors C5-11. X1, C3 and C4 provide the 8 MHz signal for the clock of the microcontroller. R12 and R13 provide pull downs for correct operation of the internal processor communications channel. C12 provides supply decoupling for the microcontroller and VR1 sets the contrast of the LCD display.

IC2 is a dual op-amp whose purpose is to control the output power of the transmitter. Side A of the op-amp is configured as a unity gain buffer for the PWM and was described previously. VR2 provides an adjustable DC level to side B of the op-amp. Side B is configured as a DC amplifier with the gain set by R17, R18, R19, R20 and R25. The larger the DC signal provided by side A and the larger the DC signal at the output of Side B. This DC signal is used to turn down the output of the Power amplifiers power supply and with it the RF power output level.

LED3 and R20 provide a connection from the reverse RF power sensor into the input the non inverting input of side B of the op-amp. LED3 only allows DC through above a certain level. Any DC above this level will increase the output voltage from the op-amp and the RF power level will decrease. This forms the VSWR protection for the transmitter. LED1 and LED2 also provide the same function but with the DC level this time being supplied by the temperature sensor on the PA board. Too high a temperature will cause the DC level to exceed the turn on point of the two diodes and voltage will once again turn up the op-amps voltage and turn down the RF power level which should lower the temperature of the transmitter. The output from side B is fed to the switched mode power supply of the power amplifier via R21 and CON1. R22 and C15 provide supply decoupling for the op-amp. C14,15,16,17,18 provide further decoupling and feedback for the power control feedback loop formed around side B of the op-amp.

3.23 POWER AMPLIFIER BOARD

The RF signal from the exciter section of the combo board arrives at the MCX RF input connector CON1 via a coaxial cable. From here the 50 ohm input impedance is matched to the gate of the FET transistor T1 by the impedance matching network formed by C1, C2, C34, L1 and L9. R1, R2, VR2 and C3 provide bias control to the gate of T1 from the output of REG1 which is a 18 volt regulator derived from the 24 Volt line of the AUX power supply module. C6 and C7 provide decoupling for the regulator. L4, C5, R3 and L3 provide 24 volts to T1's drain from the 24 volt AUX line as well as providing some impedance matching to the output of T1. Further impedance matching from T1's drain is composed of C4, L2 and VC1 and RFT1. RFT1 is a four to one balun that provides an unbalanced to balanced connection to the two Gates of gemini packaged FET transistor T2. Both gates of T2 are each biased with 2 paralled 12 Ohm resistors.

The drain outputs of T2 are connected to another balun transformer RFT2 which provides four to one impedance step up as well as proving a DC feed to the transistors drains via a center tapped winding. The DC power applied to the center of RFT2 comes from the main adjustable power supply module which can control the RF power output by having it's output voltage adjusted over a 12 to 35 volt range. C8-14, L5, and R9 provide filtering and RF decoupling to the power feed into the center tap RFT2.

The RF output side of the balun is fed into a low pass filter composed of C15-21 and inductors L6 to L8. These components reduce the level of any harmonic products generated by the power amplifier. The output of the low pass filter feeds into the VSWR sensor which generates our forward and reverse RF power measurements for metering and for VSWR fault protection and alarms. The RF line passes through ferrite ring RFT3. This ring also has 14 turns of wire as a secondary winding. IC1 and associated resistors R13-R26 buffer the sensors outputs and provide a level suitable for the control/LCD boards microcontroller and protection circuitry.

The RF output sniff for the front panel is realized by R34 which is placed very close to the RF output line. A coaxial cable connects this picked up RF output to the front panel.

A temperature sensor circuit is located close to the main RF transistor T2. This temperature sensor is mounted into the heatsink and consists of the sensor itself TS1 which is located under the board and an op-amp circuit for level adjustment. The op-amp IC2 and associated components R10 and R27-R32 convert the output signal from the sensor itself to a level more suitable for the microcontroller and protection circuitry on the Control / LCD board.

CON2 connection block provides an interface to the board for the power connections from the two power supply modules. CON5 provides an interface to the LCD control board. This connector carries readings for the forward and reverse power, temperature, PA voltage, 18 volts from the regulator off the AUX power line to power the LCD control board and the combo board, and last but not least the PA power modules control line which controls it's output voltage. This control signal is derived from the LCD / control board and is wired through the power amplifier PCB and out through CON2 to the power supply module.

3.3 BLOCK DIAGRAM

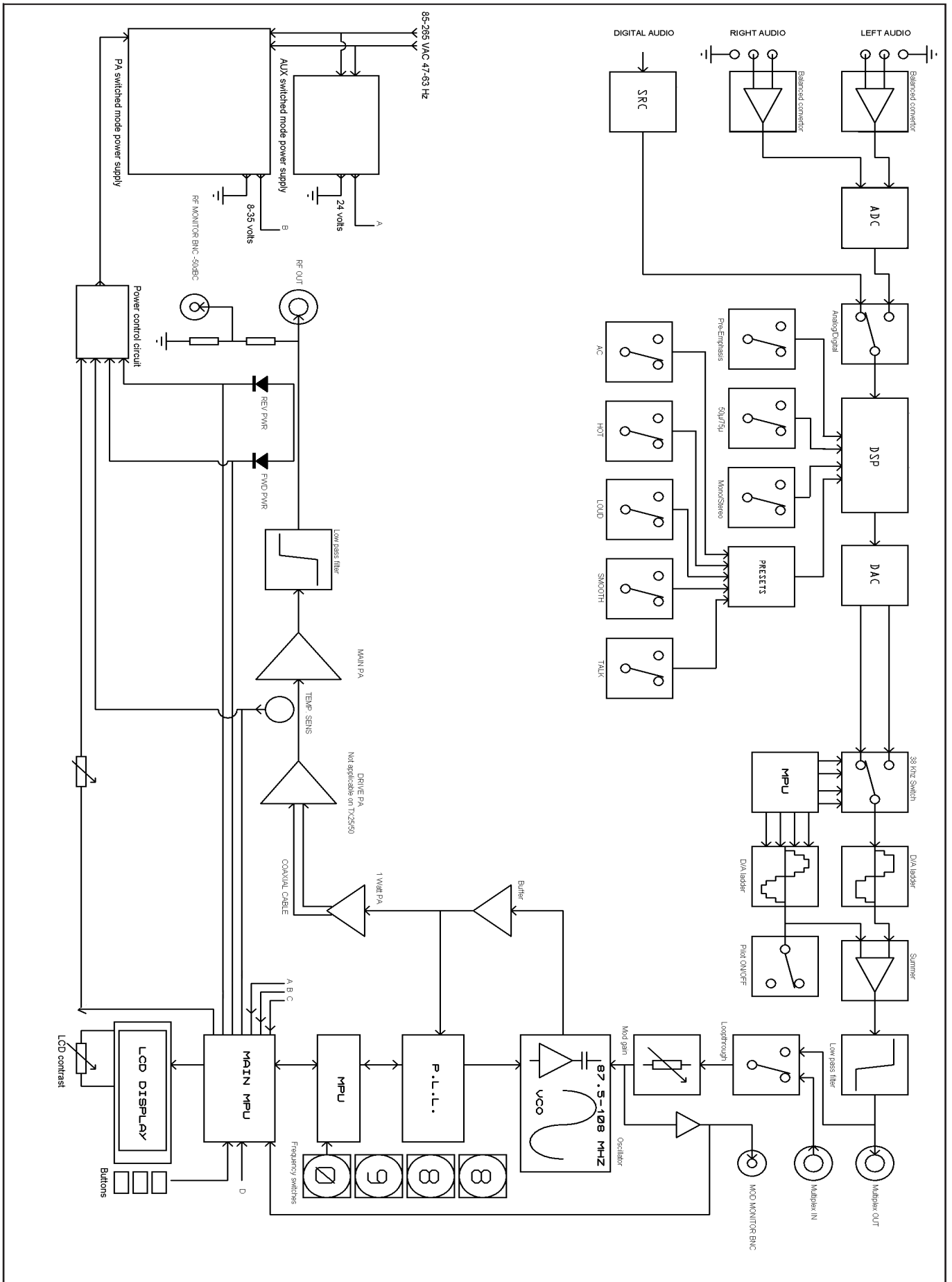

3.4 WIRING AND INTERNAL OVERVIEW

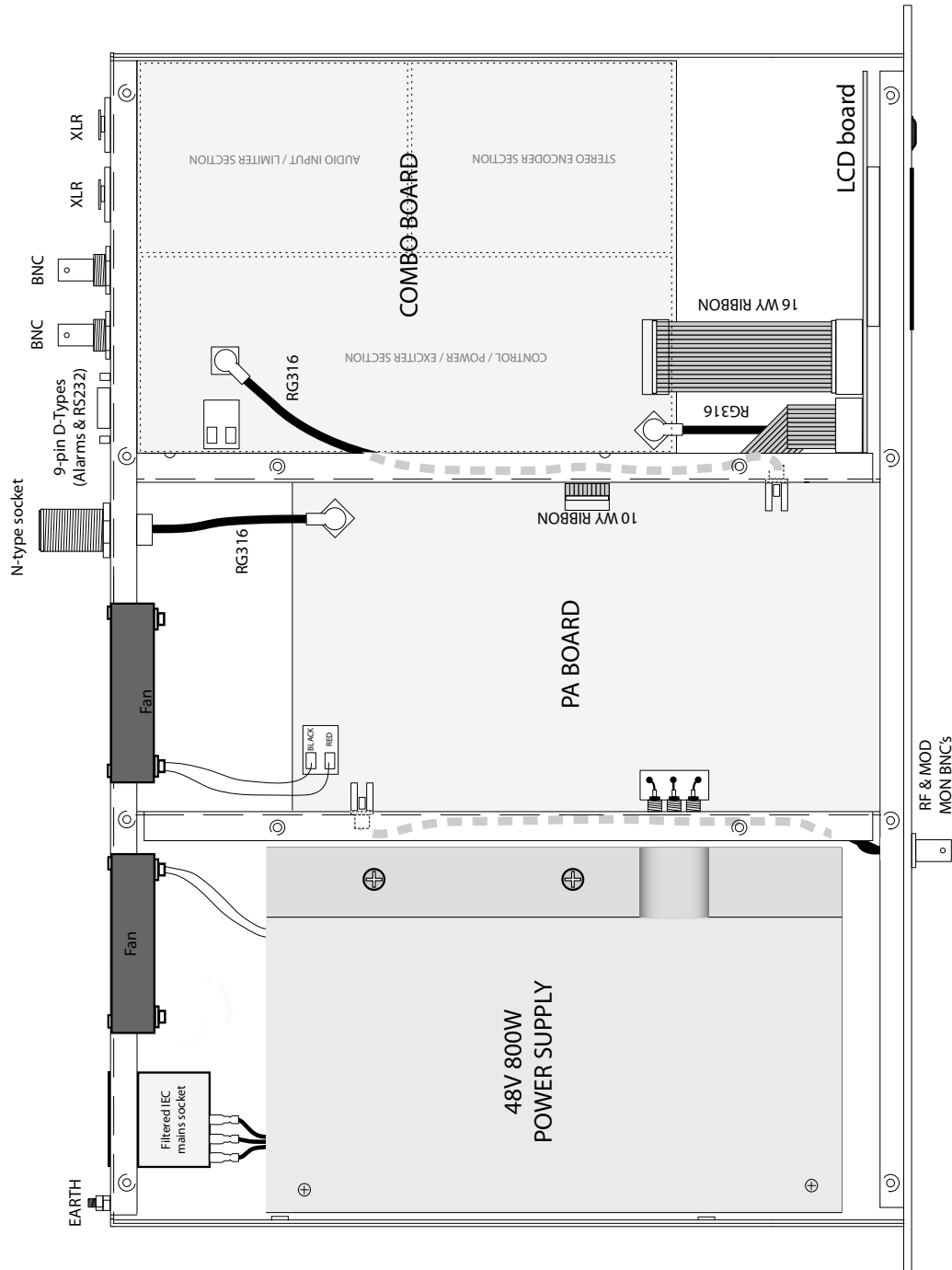

3.51 COMBO BOARD SCHEMATICS

3.511 DSP Limiter section

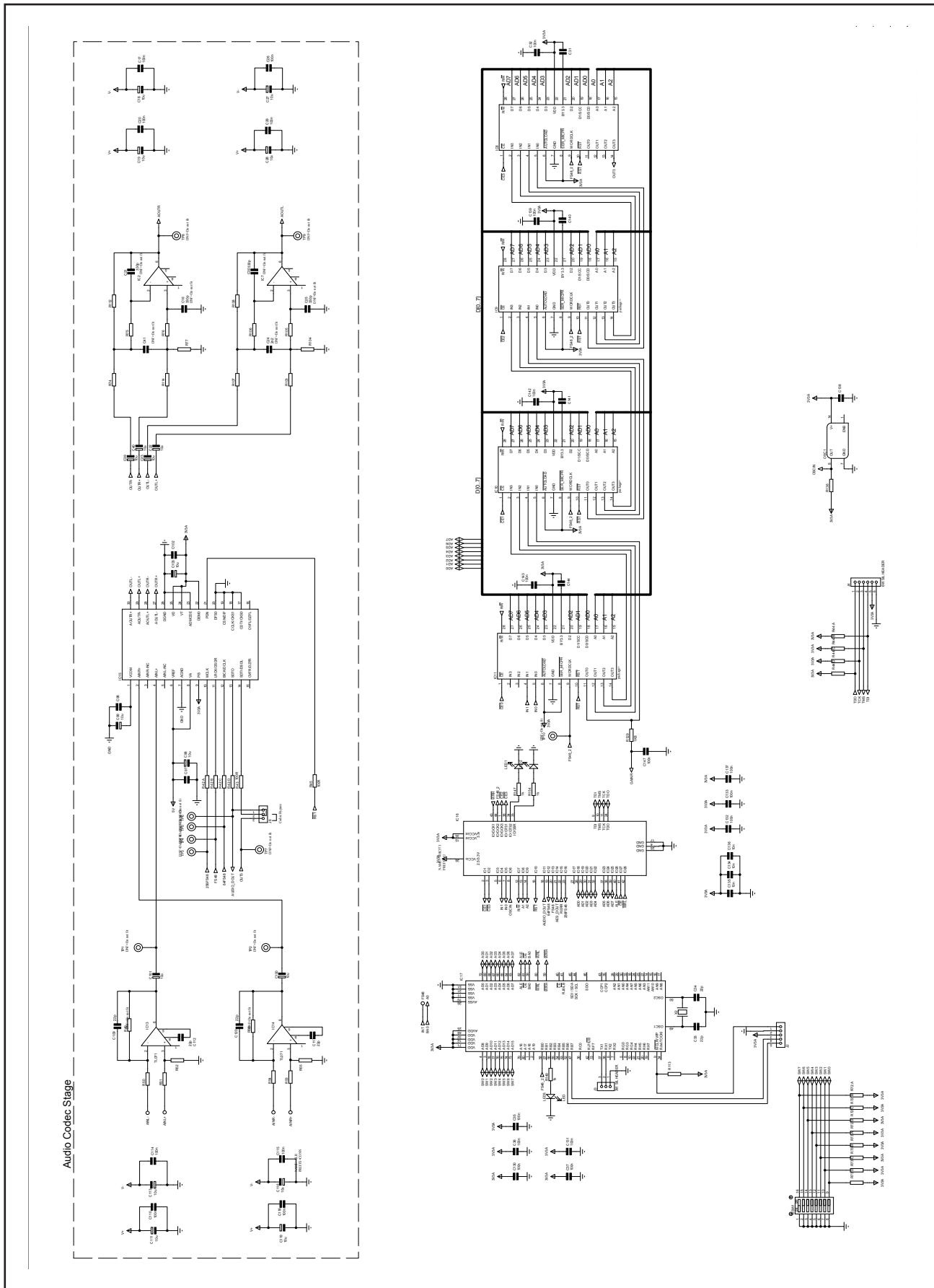

3.512 Stereo encoder section

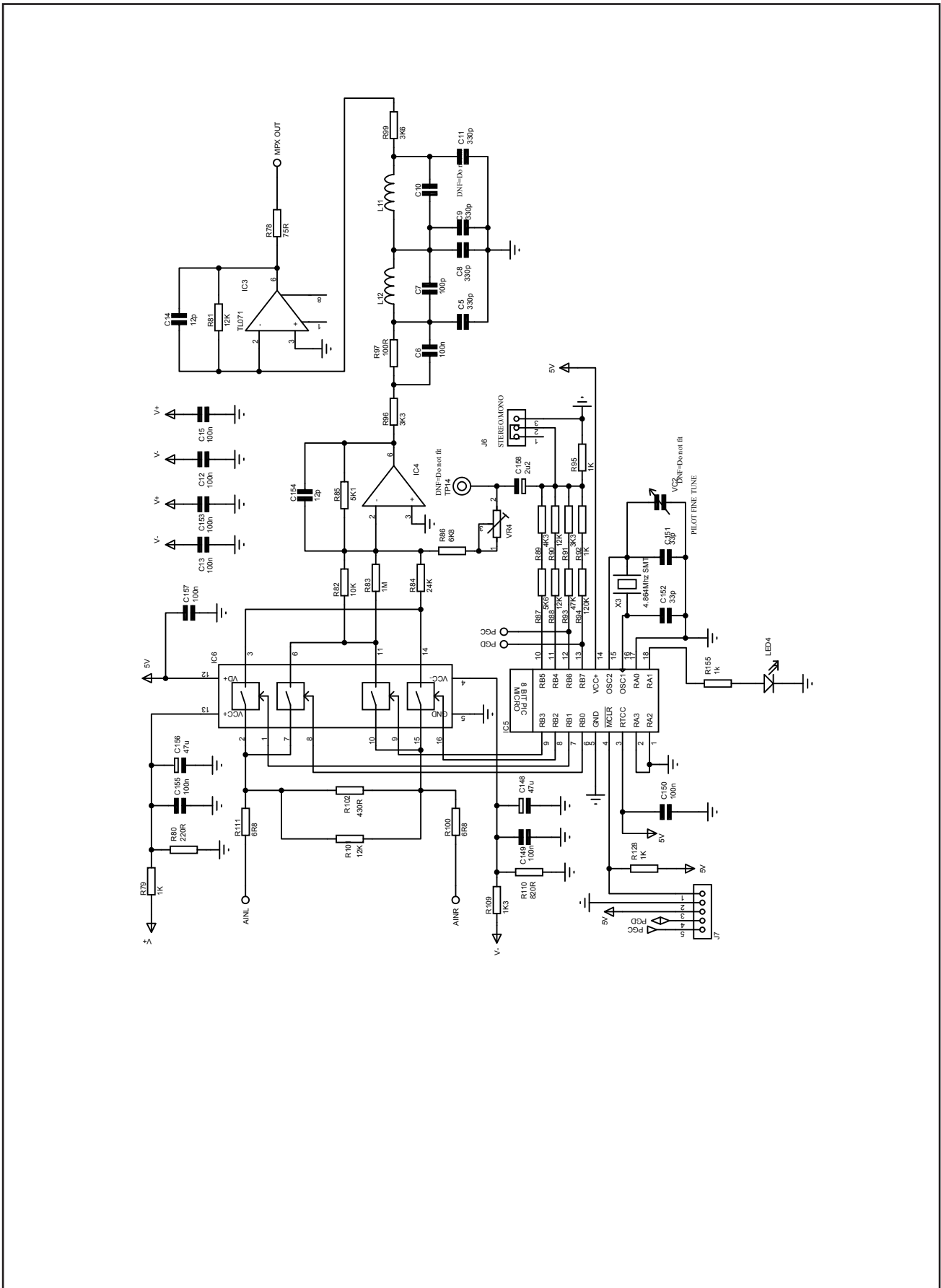

3.513 PLL exciter section

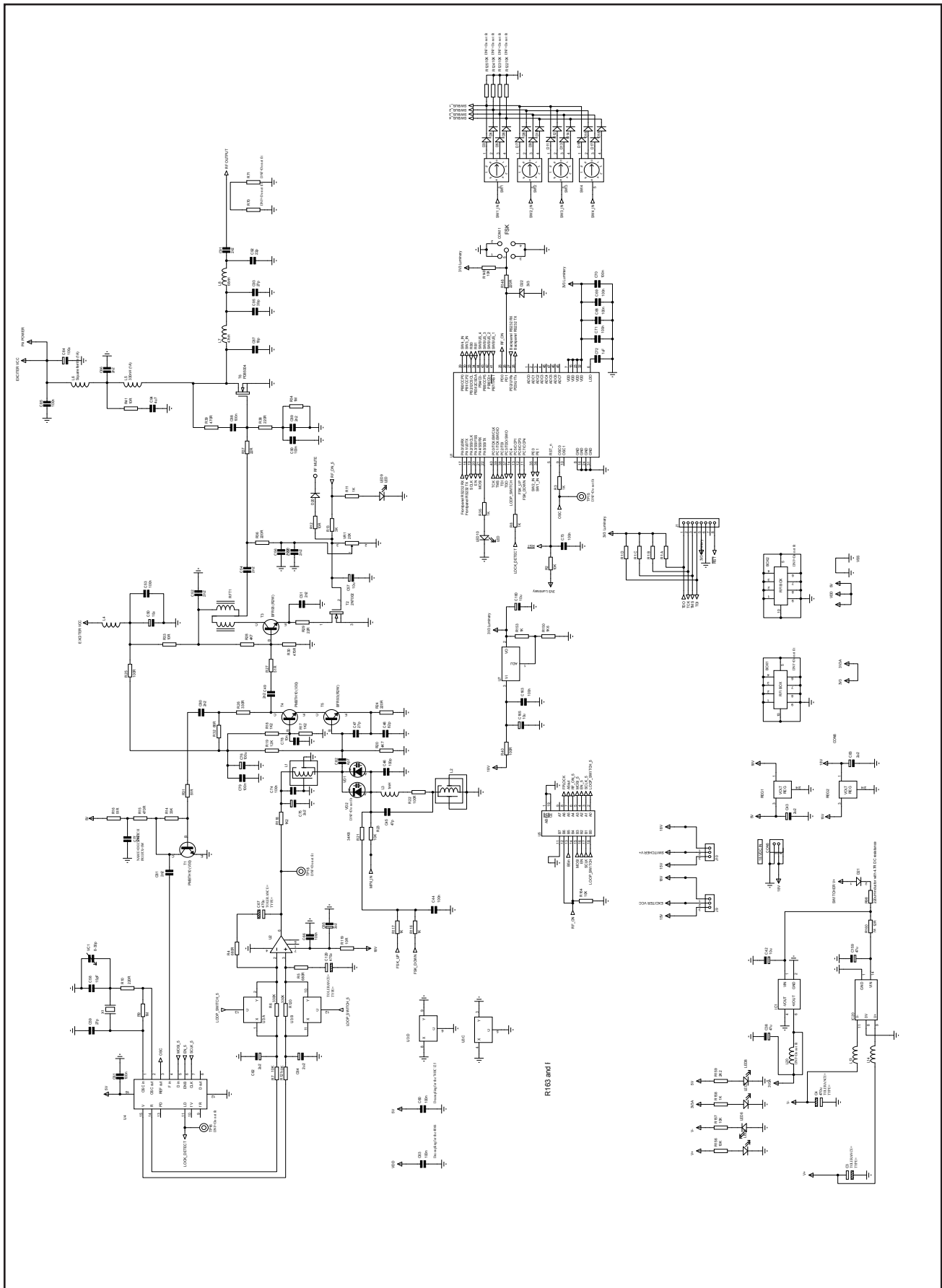

3.514 Digital Input section

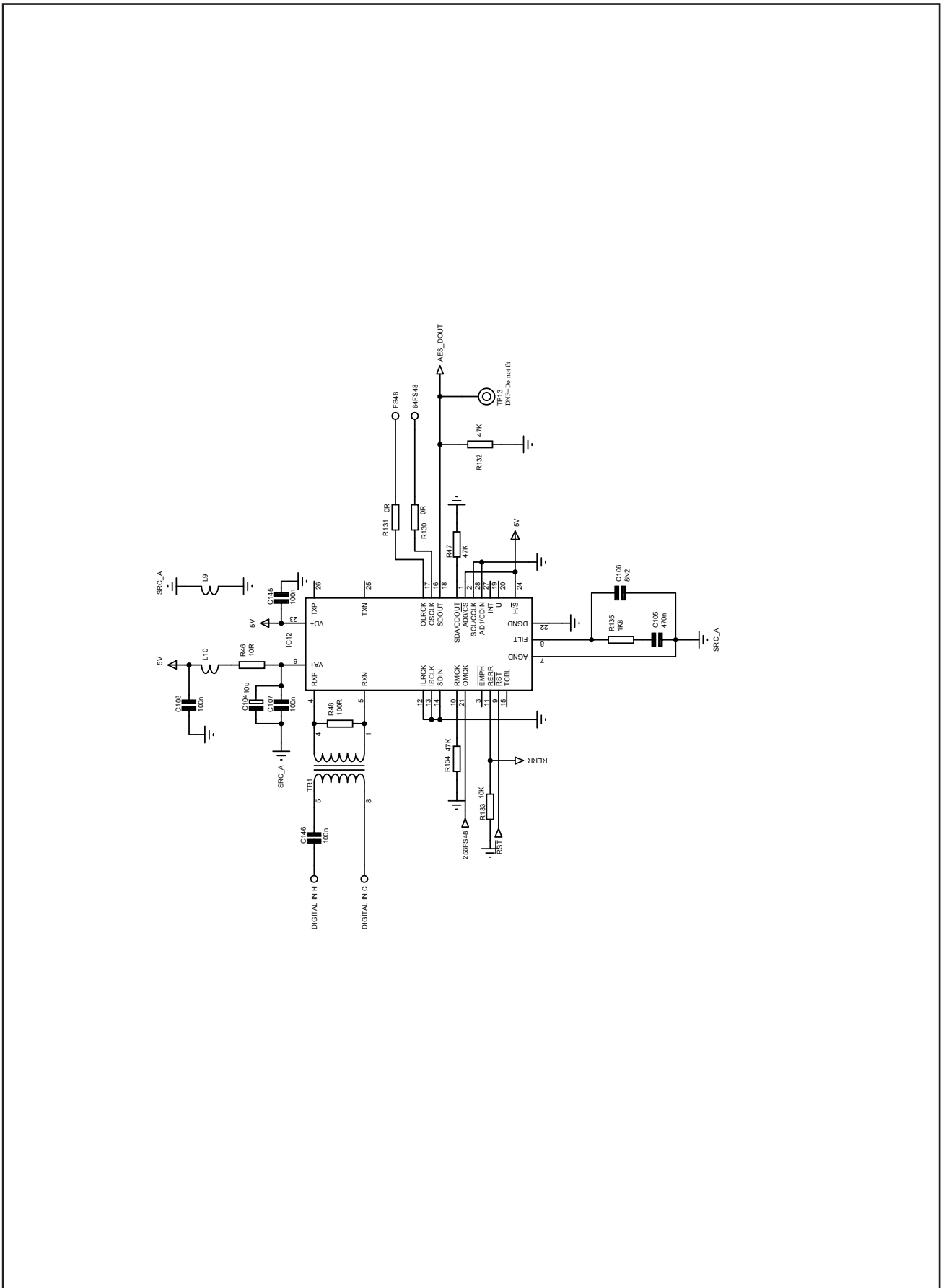

3.52 LCD CONTROL BOARD

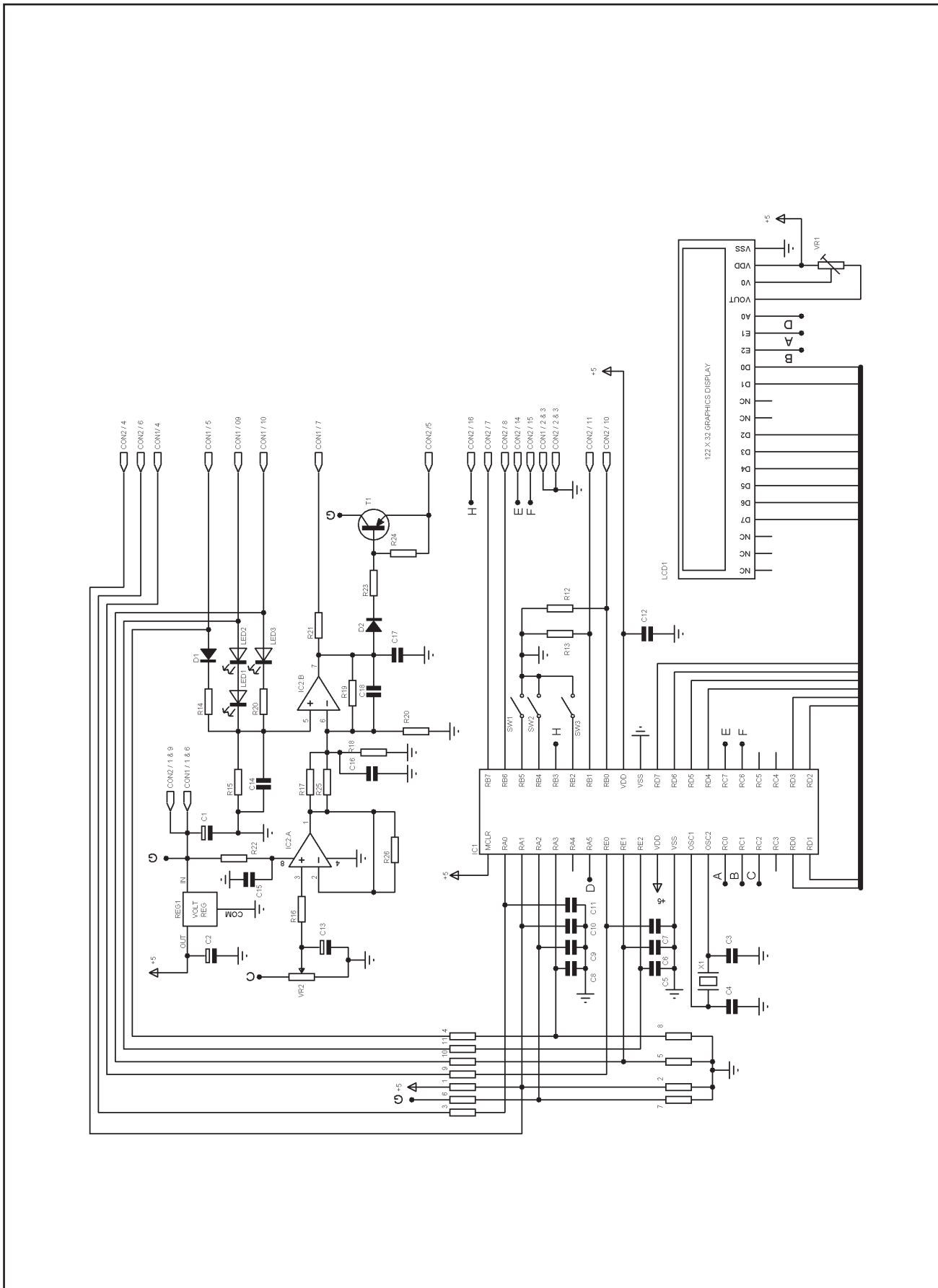

3.53 POWER AMPLIFIER BOARD

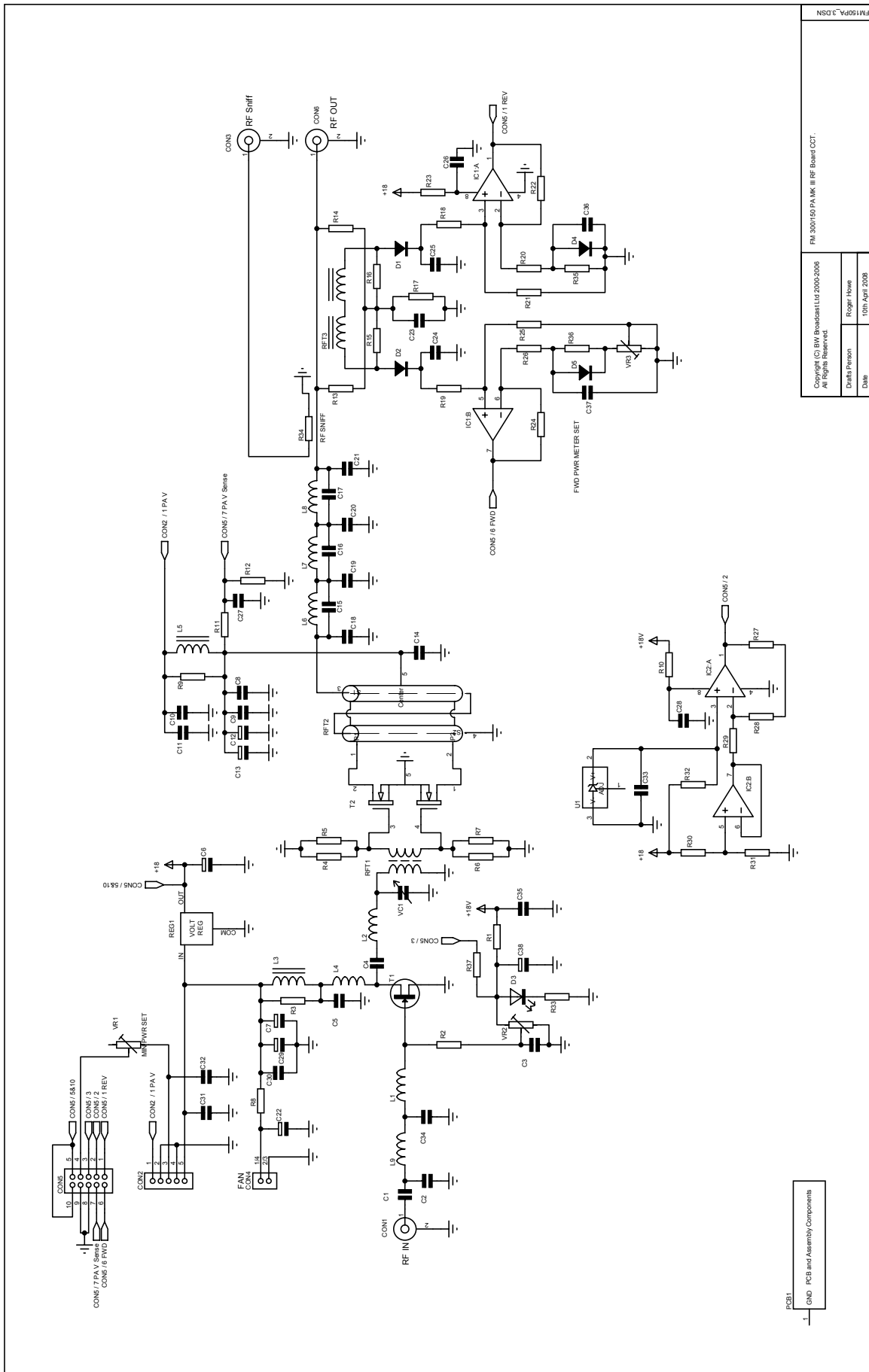

Copyright (C) BW Broadcast Ltd 2000-2008
All Rights Reserved.
Death Person Roger Howe
Date 10th April 2008

FM300150 PAM III RF Board CCT.
FM300150 PAM III RF Board CCT.

3.6 PARTS LIST

3.61 Combo board

Quantity	Reference	Description
4	R1,R44,R72,R73	10K 0.25W 1206 Thick Film 4Way Resistor Array 5%
1	R2	10K 0.1W 0805 Thick Film Resistor 1%
4	R3,R8,R116,R117	1K 0.1W 0805 Thick Film Resistor 1%
3	R4,R5,R57	680R 0.1W 0805 Thick Film Resistor 1%
2	R6,R120	330K 0.1W 0805 Thick Film Resistor 1%
9	R7,R23,R50,R51,R53,R54,R82,R121,R133	10K 0.1W 0805 Thick Film Resistor 1%
1	R9	1M 0.1W 0805 Thick Film Resistor 1%
2	R10,R146	220R 0.1W 0805 Thick Film Resistor 1%
7	R11,R35,R59,R79,R92,R95,R128	1K 0.1W 0805 Thick Film Resistor 1%
6	R12,R33,R41,R46,R61,R119	10R 0.1W 0805 Thick Film Resistor 1%
1	R13	3K 0.1W 0805 Thick Film Resistor 1%
1	R14	33K 0.1W 0805 Thick Film Resistor 1%
3	R15,R30,R58	470R 0.1W 0805 Thick Film Resistor 1%
4	R16,R27,R31,R69	51R 0.1W 0805 Thick Film Resistor 1%
9	R17,R18,R62-R67,R118	1K2 0.1W 0805 Thick Film Resistor 1%
5	R19,R81,R88,R90,R101	12K 0.1W 0805 Thick Film Resistor 1%
12	R20,R28,R68,R74,R77,R103,R104,R107, R108,R112-R114	4K7 0.1W 0805 Thick Film Resistor 1%
1	R21	34K8 0.1W 0805 Thick Film Resistor 1%
6	R22,R25,R43,R45,R48,R97	100R 0.1W 0805 Thick Film Resistor 1%
3	R24,R36,R38	220R 0.1W 0805 Thick Film Resistor 1%
1	R26	330R 0.1W 0805 Thick Film Resistor 1%
2	R29,R37	22R 0.1W 0805 Thick Film Resistor 1%
1	R32	68R 0.1W 0805 Thick Film Resistor 1%
2	R34,R83	1M 0.1W 0805 Thick Film Resistor 1%
1	R39	470R 1W 2512 Thick Film Resistor 5%
1	R40	100R 1W 2512 Thick Film Resistor 5%
1	R42	100R 0.25W 1206 Thick Film 4Way Resistor Array 5%
4	R47,R93,R132,R134	47K 0.1W 0805 Thick Film Resistor 1%
4	R49,R52,R55,R56	820R 0.1W 0805 Thick Film Resistor 1%
4	R60,R129,R135,R136	1K8 0.1W 0805 Thick Film Resistor 1%
4	R75,R76,R105,R106	200R 0.1W 0805 Thick Film Resistor 1%
3	R78,R126,R127	75R 0.1W 0805 Thick Film Resistor 1%
1	R80	220R 0.1W 0805 Thick Film Resistor 1%
1	R84	24K 0.1W 0805 Thick Film Resistor 1%
1	R85	5K1 0.1W 0805 Thick Film Resistor 1%
1	R86	6K8 0.1W 0805 Thick Film Resistor 1%
1	R87	5K6 0.1W 0805 Thick Film Resistor 1%
1	R89	4K3 0.1W 0805 Thick Film Resistor 1%
2	R91,R96	3K3 0.1W 0805 Thick Film Resistor 1%
1	R94	120K 0.1W 0805 Thick Film Resistor 1%

1	R98	220uH Axial Inductor Ferrite 5% Tolerance
1	R99	3K6 0.1W 0805 Thick Film Resistor 1%
2	R100,R111	6R8 0.1W 0805 Thick Film Resistor 1%
1	R102	430R 0.1W 0805 Thick Film Resistor 1%
1	R109	1K3 0.1W 0805 Thick Film Resistor 1%
1	R110	820R 0.1W 0805 Thick Film Resistor 1%
2	R130,R131	0R 0805 Thick Film Resistors 0.125W 1%
4	R137-R140	10R 0.1W 0805 Thick Film Resistor 1%
5	R147,R153-R155,R158	1K 0.1W 0805 Thick Film Resistor 1%
4	R148,R156,R157,R164	10K 0.1W 0805 Thick Film Resistor 1%
1	R149	4K7 0.1W 0805 Thick Film Resistor 1%
1	R150	1K6 0.1W 0805 Thick Film Resistor 1%
1	R151	10R 0.25W 1206 Thick Film 4Way Resistor Array 5%
1	R159	2K2 0.1W 0805 Thick Film Resistor 1%
1	R160	12R 1W 2512 Thick Film Resistor 5%
1	C1	220pF 0805 Multi-layer Ceramic 50V C0G / NP0 Capacitor
	C2,C18,C19,C22,C23,C27,C28,C39,C40,C42,C9	
	6,C99-C101,C103,C104,C111,C113,C116,C119,C	
22	160,C165	10uF 4mm Diameter SMD Elec Can 16V Capacitor
4	C3,C4,C67,C129	470uF 8mm Diameter SMD Elec Can 16V Capacitor
4	C5,C8,C9,C11	330pF 0805 Multi-layer Ceramic 50V X7R Capacitor
	C6,C12,C13,C15,C17,C20,C26,C29,C31,C32,C44	
	,C53,C56,C60,C61,C63,C66,C68-C71,C73,C74,C	
	79,C85,C88,C90,C97,C98,C102,C107,C108,C110,	
	C114,C115,C118,C122,C124-C128,C138-C147,C1	
58	49,C150,C153,C155,C157,C163	100nF 0805 Multi-layer Ceramic 50V X7R Capacitor
2	C7,C46	100pF 0805 Multi-layer Ceramic 50V C0G / NP0 Capacitor
2	C14,C154	12pF 0805 Multi-Layer Ceramic 50V C0G / NP0 Capacitor
5	C33,C34,C92,C112,C117	22pF 0805 Multi-layer Ceramic 50V C0G / NP0 Capacitor
8	C35-C37,C130-C133,C137	100nF 0603 Multi-layer Ceramic 50V X7R Capacitor
4	C38,C148,C156,C159	47uF 6.3mm Diameter SMD Elec Can 16V Capacitor
7	C43,C62,C64,C65,C75,C83,C158	2.2uF 4mm Diameter SMD Elec Can 50V Capacitor
1	C45	47pF 0805 Multi-layer Ceramic 50V C0G / NP0 Capacitor
3	C47,C59,C93	27pF 0805 Multi-layer Ceramic 50V C0G / NP0 Capacitor
1	C48	82pF 0805 Multi-layer Ceramic 50V C0G / NP0 Capacitor
	C49,C51,C52,C54,C55,C77,C80,C81,C86,C89	
11	,C91	2n2 0805 Multi-layer Ceramic 50V X7R Capacitor
2	C50,C57	10uF 4mm Diameter SMD Elec Can 25V Capacitor
1	C58	15pF 0805 Multi-layer Ceramic 50V C0G / NP0 Capacitor
1	C72	1uF 0805 Multi-layer Ceramic 50V X7R Capacitor
2	C76,C84	100uF 6.3mm Diameter SMD Elec Can 16V Capacitor
1	C78	10nF 0805 Multi-layer Ceramic 50V X7R Capacitor
1	C82	4p7 0805 Multi-layer Ceramic 50V C0G / NP0 Capacitor
1	C87	18pF 0805 Multi-layer Ceramic 50V C0G / NP0 Capacitor
1	C94	4.7uF 0805 Multi-layer Ceramic 25V X5R / X7R Capacitor
1	C95	39pF 0805 Multi-layer Ceramic 50V Capacitor 1%
1	C105	470nF 0805 Multi-layer Ceramic 50V X7R Capacitor
1	C106	8200pF 0805 Multi-layer Ceramic 50V Capacitor 5%

3	C134-C136	10nF 0603 Multi-layer Ceramic 50V X7R Capacitor
2	C151,C152	33pF 0805 Multi-layer Ceramic 50V Capacitor 1%
1	IC1	B3-153R3SS 2W SIL Single Output DC To DC Converter 3.3V Out
2	IC2,IC7	NE5534D Low Noise Op-Amp SOP8.225
4	IC3,IC4,IC13,IC14	TL071 Single Op-Amp 3MHz SOP8.225
1	IC5	PIC16F627A-I/SO 8Bit Flash Micro-Controller SOIC18
1	IC6	HI3-0201HS-5Z High Speed Quad SPST
4	IC8-IC11	AL3101CG Dual Volt DSP SOIC-28
1	IC12	CS8420-CSZ Digital Audio Sample Rate Converter SOP28.375
1	IC15	AK4620B 24-Bit 192kHz Audio CODEC with IPGA
1	IC16	XC9572XL-10VQG44C In-System Programmable CPLD
1	IC17	PIC18F87K22-I/PT 8 bit Micro-Controller TQFP80
1	IC18	TL072CD Dual FET Op Amp SOIC8
1	IC19	MAX232 RS232 Dual Transceiver SOJ16
1	IC20	12-15 2W DIL Dual Output DC To DC Converter
1	U1	LM3S608 Luminary Microcontroller LQFP48 Package
1	U2	NE5534D Low Noise Op-Amp SOP8.225
1	U3	HEF4066BT Quad Bilateral Analogue Switch SOIC14
1	U4	MC145170P2 SOP16.225 PLL Freq Synthesizer Serial Interface
1	U5	74HCT245 Quad Buffer Line Driver SOIC20
1	U7	LM317 1.5A Adjustable Linear Regulator
17	D3-D18,D20	1N4148 100V High Speed Switching Diode SOD-323 Package
1	D21	1N4001 SSot-6 1A 50V Miniature Plastic Diode
1	D22	Generic Zener Diode 3.3V 400mW SOD323 Package
1	J1	8 Pin 2.54mm Pitch SIL Straight PCB Mount Header
2	J2,J7	5 Pin 2.54mm Pitch SIL Straight PCB Mount Header
6	J3,J5,J6,J8-J10	3 Pin 2.54mm Pitch SIL Straight PCB Mount Header
1	J4	6 Pin 2.54mm Pitch SIL Straight PCB Mount Header
2	J11,J12	4 Pin 2.54mm Pitch SIL Straight PCB Mount Header
2	J13,J14	3 Pin 2.54mm Pitch SIL Straight PCB Mount Header
3	CON1,CON4,CON11	MCX Jack Straight PCB Mount Receptacle 50Ohm
1	CON2	16 Way 2.54mm Pitch Straight PCB Mount Boxed Header
1	CON5	2 Way Screwless 45 degree PCB Mount Terminal Block
1	CON6	Filtered Dual 9 Way Right Angle PCB Mount D-Type Connector
2	CON7,CON8	BNC Right Angle PCB-Mount Non-insulated Connector 50Ohm
2	CON9,CON10	3Pin XLR Female R/A PCB Mount Non-Insulated Chassis Socket
1	CON12	10 Way 2.54mm Pitch Straight PCB Mount Boxed Header
1	DSW1	8 Way SPST 2.54 Pitch SO-16 Slide Switch
12	FIL3-FIL12,FIL15,FIL16	1nF 2606 Package Suppression T-Filter
10	LED1-LED10	0805 Green LED
1	OSC1	12.288Mhz 14 Pin Oscillator 100ppm DIL14
1	REG1	L7805CV +5V 1A, Linear Fixed Voltage Regulators
1	REG2	L7815CV +15V 1A, Linear Fixed Voltage Regulator TO220
1	RFT1	28SWG (0.355mm) Blue/Green Bonded Bifilar Enamelled Wire
4	SW1-SW4	10 Step Decimal Rotary PCB Switch Hole Through

1	SW6	Miniture Right Angle SMTAllOne Switch
2	T1,T4	MMBTH10LT1G NPN SOT23 Bipolar Transistor
1	T2	N-Channel Enhancement-Mode MOSFET Transistor
2	T3,T5	BFR93A NPN 6 GHz wideband transistor
1	T6	PD85004 RF Power Transistor (LdmoS Family)
3	T7-T9	BC817 SOT-23 NPN Transistor
1	TR1	AES 1:1 Transformer S5612LF
1	VC1	8-30pF 4mm Surface Mount Variable Capacitor
1	VD1	BB809 VHF variable capacitance diode (obselete)
1	VR1	20K 4mm SMT 3314J Closed Frame Cermet Trimmer
1	VR2	200R 4mm SMT Bournes 3314J Closed Frame Cermet Trimmer
1	VR3	10k 3/4IN Bourns 3006P Horizontal Cermet Trmmer
1	VR4	10K 4mm SMT Bournes 3314J Closed Frame Cermet Trimmer-
1	X1	10.000MHz HC-49/S SMT Crystal
1	X2	4.9152MHZ HC49S SMD Crystal 30/50/-10 60/30 ESR=30
1	X3	4.864MHz HC-49/S Surface Mount Crystal
1	L1	114 (MC120)Toko Radial Inductor Space Wound with Can
1	L2	110 (MC141)Toko Radial Inductor Close Wound with Can
1	L3	1mH 5% SMD 0805 Inductor
3	L4,L9,L10	200mA Bead Inductor 10% 0805 600R at 100MHZ
1	L5	330nH 10% SMD 1008 Ferrite Inductor
1	L6	Bead Inductor 10% 0805 600R 100MHZ
1	L7	47nH MidiSpring Inductor
1	L8	68nH MidiSpring Inductor
1	L11	4.7mH 10RB Toko Radial Inductor #181LY-472J
1	L12	3.9mH 10RB Toko Radial Inductor #181LY-392J
2	L13,L14	220uH Axial Inductor Ferrite 5% Tolerance

3.62 LCD control board

Qty	Reference	Value	Description
4	C1, C2, C13, C18	2.2uF	63V Electrolytic Cap
2	C12, C15	100n	2.5mm Pitch Radial Multilayer Ceramic (Y5V)
2	C3, C4	33pF	33pF Ceramic 2.5mm Pitch
10	C5, C6, C7, C8, C9, C10, C11, C14, C16, C17	560pF	560pF Ceramic
1	D1	1N4148	1N4148
1	LED1	3mm	Mini 3mm Green LED - L-7104GD
1	LED2	3mm	Mini 3mm Red LED - L-7104GD
3	R1, R2, R16	33k	1/8 W Metal Film 1% - CR12
3	R12, R13, R14	1k8	1/8 W Metal Film 1% - CR12
4	R15, R18, R20, R22	100R	1/8 W Metal Film 1% - CR12
1	R17	560R	1/8 W Metal Film 1% - CR12
1	R19	100k	1/8 W Metal Film 1% - CR12
6	R3, R7, R8, R9, R10, R11	820R	1/8 W Metal Film 1% - CR12
2	R4, R5	390R	1/8 W Metal Film 1% - CR12
1	R6	10k	1/8 W Metal Film 1% - CR12
1	R21	4k7	1/8 W Metal Film 1% - CR12
1	R23, R24	4R7	1/8 W Metal Film 1% - CR12
1	R25	1K	1/8 W Metal Film 1% - CR12
1	VR3	200R	Bourns 3296 W 3/8in
1	VR1	500R	Bourns Minipot
1	VR2	100k	Minipot Spectrol 63M
1	Reg1	7805	7805CV 1A VOLTAGE REGULATOR
1	IC1	40 Pin	40 Pin PIC16F877-20P (NOT FITTED)
1	IC2	CA3240EZ	CA3240 Op Amp
0	IC3	TBA	NOT FITTED
3	SW1-3	9.5mm	9mm Tactile Switch
1	X1	8MHz	8MHz Crystal
1	Connector	20-Way	Header Strip (20-Way)
1	LCD Screen	LCD	Blue LCD Display
1	IC1	40-Pin	40 Pin IC Socket
2	IC2,IC3	8-Pin	8-Pin IC Socket
3	Panel Buttons	n/a	Molded Cap for Switch (NOT FITTED)
1	Con1	10-Way	10 Way Boxed Header
1	Con2	16-Way	16 Way Boxed Header

3.63 Power amplifier board

Qty	Reference	Value	Description
2	R1,R31	3k3	1/4W Metal film resistor
2	R1,R31	3k3	1/4W Metal film resistor
5	R2,R18,R19,R21,R25	470R	1/4W Metal film resistor
2	R3,R8	12R	1/4W Metal film resistor
6	R4-R7,R15,R16	12R	SMT Chip resistor 120
1	R9	N.F.	NOT FITTED
3	R10,R23,R33	75R	1/4W Metal film resistor
1	R11	6k8	1/4W Metal film resistor
1	R12	560R	1/4W Metal film resistor
2	R13,R14	22K	SMT Chip resistor 223
1	R17	330R	SMT Chip resistor 331
2	R20,R26	1K5	1/4W Metal film resistor
4	R22,R24,R27,R29	10k	1/4W Metal film resistor
2	R28,R32	18k	1/4W Metal film resistor
1	R30	13k	1/4W Metal film resistor
1	R34	47R	1/4W Metal film resistor
2	R35,R36	1k3	1/4W Metal film resistor
1	R37	??	OPTIONAL 1/4W Metal film resistor
1	VR1	10k	63M series - top screw adjustment
2	VR2,VR3	1K	Top screw adjustment
1	C1	47pF	5mm Pitch Ceramic Cap
1	C2	27pF	2.5mm Pitch Ceramic Cap
15	C3,C8-C11,C24-C28,C30-C33,C35	10nF	2.5mm Pitch Ceramic Cap
2	C4,C34	150pF	2.5mm Pitch Ceramic Cap
1	C5	330pF	5mm Pitch Ceramic Cap 683 series
3	C6,C7,C38	2.2uF	1.5mm Pitch Mini Radial Electrolytic
4	C12,C13,C22,C29	100uF	Electrolytic 105deg
1	C14	1uF	5mm Miniture Polyester Cap
1	C15	12pF	SEMCO Metal Clad Cap - MIN02-002
1	C16	10pF	SEMCO Metal Clad Cap - MIN02-002
1	C17	8pF	SEMCO Metal Clad Cap - MIN02-002
3	C18-C20	33pF	SEMCO Metal Clad Cap - MCM01-001
1	C21	15pF	SEMCO Metal Clad Cap - MCM01-001
1	C23	8p2	2.5mm Pitch Ceramic Cap 680 series
2	C36,C37	N.F.	OPTIONAL
1	VC1	5-65pF	Miniature trimmer capacitor
1	L1	IND-AIR	AgCu - 0.9mm half loop link
1	L2	IND-AIR	3.5T S18 Inductor
2	L3,L5	IND-IRON	Radial Ferrite Bead Inductor- 6A Murata
1	L4	IND-AIR	8 Turn coil, (self fluxing wire)
2	L6	IND-AIR	14 Gauge - SC2.0X7.8X2.5T-3
1	L7	IND-AIR	14 Gauge - SC2.0X7.8X3.5T-3
1	L8	IND-AIR	14 Gauge - SC2.0X7.2X3.5T-4
1	L9	IND-AIR	2.5T S18 Inductor
1	D1,D2	DIODE2	Single Diode Silicon schottky BAT42
1	D3	LED	5mm Pitch Green LED-L-53 series
2	D4,D5	DIODE2	OPTIONAL
1	T1	FET	N Channel Power MOSFET IRL510 5.6A
2	T2	DUALFET	BLF278 Power Transistor
1	IC1,IC2	TL072	CA3240EZ 8-pin Op-Amp
2	IC3,IC4	8-Pin	8-Pin IC Holder
1	CON1,CON3	COAXSOCKET	MCX PCB Connector

1	CON2	CONN-H5	OPTIONAL 5-Way 45deg Terminal
2	CON4	CONN-H2	2-Way 45deg Terminal
2	CON5	CONN-DIL10-IDC	RA IDC Ribbon Connector
2	CON6	COAXSOCKET	NOT FITTED



bw broadcast

www.bwbroadcast.com